

Showmanship - W/T

Blue = 100% - 85% Red = 84% - 70% White = 69% -

#	Comments	Score	Danish	Placing
270	Look up, P.F. Sawdust on belly	87	B	2
134	Hold Pretty nice pattern. Practice your 1/4 ing	85	B	1
101	Halt, Practice 1/4 ing. Can fix horse position when they move.	84	R	3

pk

Showmanship - Junior

High Blue = 92%-100% (medals program qualification) Blue = 91% - 85% Red = 84% - 70% White = 69%-

#	Comments	Score	Danish	Placing
109	_____			
130	No trot, should not touch horse to back or turn on haunches	69	W	8
115	Broke at trot, don't switch hands to back. Practice 1/4ing	75	R	7
131	Work on F.H. turn. No 2 hands on lead.	84+	R	4
132	Fairly nice pattern. A little slow to 1/4.	88	B	2
106	Broke at trot. No 2 hands on lead. Practice 1/4ing	84	R	6
105	Broke at trot Presented well. No 2 nd trot	84+	R	5
116	Presented well. Slow to 2 nd trot	89	B	1
128	F.H. - work on it Presented well.	85	B	3

PLX

- needs to go 1st

Showmanship - Intermediate

High Blue = 92%-100% (medals program qualification) Blue = 91% - 85% Red = 84% - 70% White = 69%-

#	Comments	Score	Danish	Placing
225	Horse fidgety @ cone. Circling. Anxious work on walk off pattern. Kudos to handler for containing	40%	W	
207	Fidgety @ cone. Work to be straight. on Needs need two hands on lead for haunch turn work to trot in Rhythm w/ horse. NO switching hands	45%	W	
232	Work for propo position @ cone A. Needs pivot show w/ hands above waistline. Less studder on back OK set up. Work on confidence	69%	W	8
251	Work on proper position. No switching hands for haunch turn. work to develop trot sooner. NO PHONE IN POCKET. Look to where you go	41st 4/6%	W	
205	Strong start. moved pivot foot fx. Nice circle work for more balance sup @ C set and straight back touching chain on set up. Continue to build confidence	84%	R	7
250	would like to see hand above waistline. NO switching hands for turn and back. Bring eyes up quiet shoulders when trotting. work for propo position @ judge	64%	W	
215	work on turn. good confidence, work to quiet shoulders and for wider hand position. Needs straight back. work to bring horse to judge. Needs 90° turn @ judge	84%	R	6
244	work for correct position @ cone A. Needs pivot try to be in Rhythm w/ horse @ trot. Work for correct FH turn. Bring horse to judge. fidgety @ judge	84++	R	5
235	work for consistent pivot foot. Some resistance for back but straight. work to be straight w/ judge. Needs 90° pivot foot	85%	B	3
212	work to be straight w/ judge. No touching horse for haunch turn. work for more confidence. resistance @ back	41%	W	
256	work for less resistance on turn. work for more balance stop and less resistance on back. work to be straight @ judge. Needs 90° @ judge	85%	B	4
220	stepped out of pivot. Head too far for trot no flat feet Needs forward for FH turn. work for stronger set up chain needs turned out	86%	B	1
243	work to start straight w/ judge. Needs pivot strong circle. Bring eyes up. Resistant @ back but straight. Needs pivot. Strong trot	85++	B	2



Showmanship - Senior

High Blue = 92%-100% (medals program qualification) Blue = 91% - 85% Red = 84% - 70% White = 69%-

#	Comments	Score	Danish	Placing
321	Walk forward in F.H. Sidepass could be straighter	86	B	2
347	Well presented	91.5	B	
304	—			
329	Well presented <input checked="" type="checkbox"/>	95+	B	1
315	Back a bit fussy at first over 90 F.H. Work on keeping horses head straight	75	R	5
327	Work on F.H. Work on 1/4ing Slow to sidepass.	73	R	6
396	Crisper 1/4ing No sidepass	69	W	8
339	Work on 1/4ing (can setup closer to judge)	85	B	4
335	No sidepass (can setup closer to judge)	69+	W	7
317	Back sticky. Way how you use your hands to launch turn	85+	B	3

pk

1. At A, perform a 360-degree turn.
2. Trot to B. At B, turn right and trot a circle, about 30' in diameter.
3. At B, stop. Back three steps.
4. Walk to C and set up for inspection.
5. Judge will ask a question about the parts of the horse.
6. Exhibitor is excused to line up.

Cones should be 30' apart

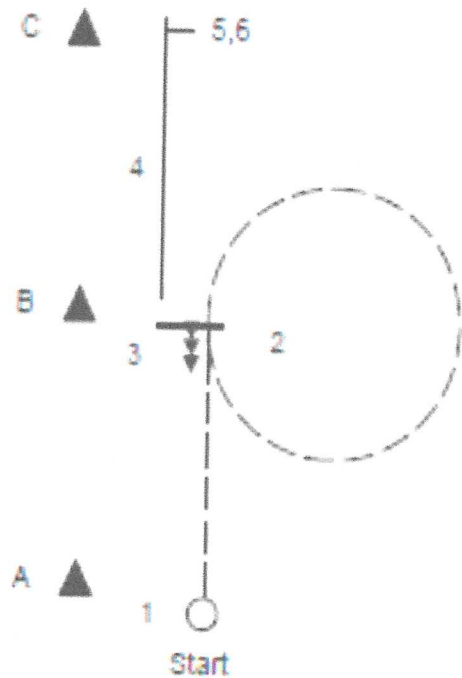

Using two body parts as reference, where is the crest?

71

Rider # 220

Comments: Needs pivot foot - Strong trot - Backed 2 steps
no shuffling feet - Nice set up
Crest is between the pole and withers

Medal: YES

NO

Judges Signature: _____

1. At A, perform a 360-degree turn.
2. Trot to B. At B, turn right and trot a circle, about 30' in diameter.
3. At B, stop. Back three steps.
4. Walk to C and set up for inspection.
5. Judge will ask a question about the parts of the horse.
6. Exhibitor is excused to line up.

Cones should be 30' apart

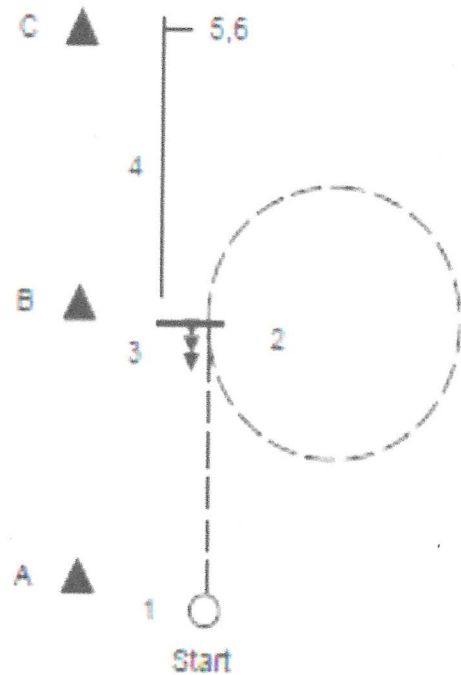

Using 2 body parts as reference where is the crest?

71

Rider # 335

Comments: Needs pivot foot. Bring hands above

wayline. ~~and~~ Needs to be straight w/judge

Answered correct

Medal: YES

NO

Judges Signature: [Signature]

1. At A, perform a 360-degree turn.
2. Trot to B. At B, turn right and trot a circle, about 30' in diameter.
3. At B, stop. Back three steps.
4. Walk to C and set up for inspection.
5. Judge will ask a question about the parts of the horse.
6. Exhibitor is excused to line up.

Cones should be 30' apart

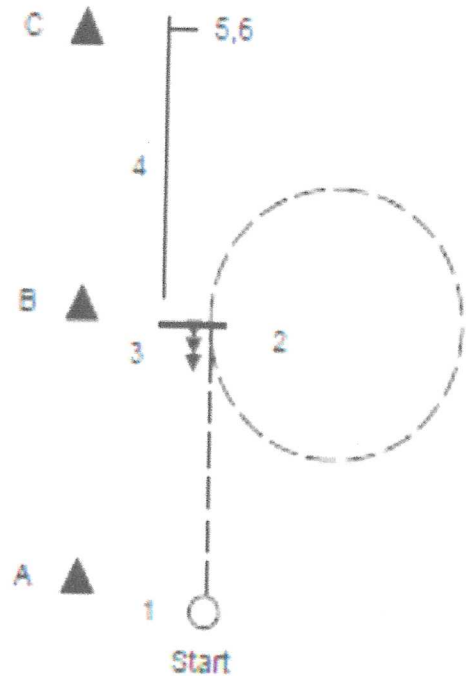

Using two body parts as reference
Where is the crest?

71

Rider # 105

Comments: work for pivot foot + less resistance

lode to foot work to quiet arms

crest is between withers + pole

Medal: YES

NO

Judges Signature: _____

1. At A, perform a 360-degree turn.
2. Trot to B. At B, turn right and trot a circle, about 30' in diameter.
3. At B, stop. Back three steps.
4. Walk to C and set up for inspection.
5. Judge will ask a question about the parts of the horse.
6. Exhibitor is excused to line up.

Cones should be 30' apart

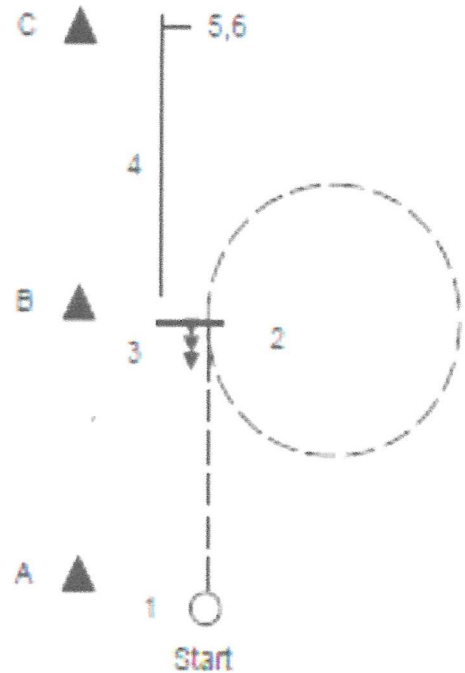

Using 2 body parts as reference
Where is the crest?

71

Rider # 225

Comments: Settle @ first cone. Needs pivot fast. off pattern

walk for more balanced stop. Horse pretty pushy

Crest is between pole + ~~with~~ the withers

Medal: YES

NO

Judges Signature: _____

1. Start at D.
2. Walk to C. Turn 90-degrees on the right forehand.
3. Back four steps.
4. Trot to B. At B, begin trotting a figure eight to the right first. Circles should be about 30' in diameter.
5. After completing figure eight, stop at B. Turn 360-degrees on the haunches.
6. Walk to A. Stop. Side pass about five steps to the right
7. Set up for inspection. After inspection, pick up forefoot judge directs.
8. Judge may ask a question.
9. Exhibitor is excused to line up.

Cones should be 30' apart

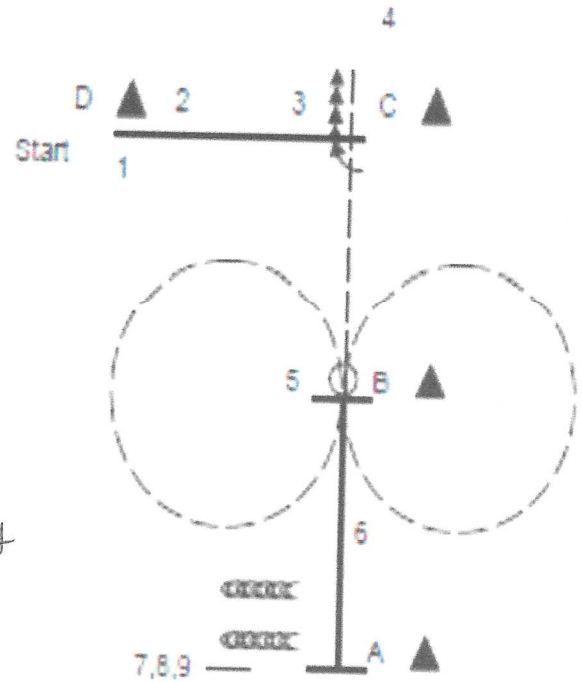

What are the 4 H's in 4H

71

Rider # 235

Comments: strong start. ~~lots of back side pass~~

needs pivot first. Resistant to back side pass.

Needs cross overs

Answer correct

Medal: YES

NO

Judges Signature: [Signature]

1. Start at F.
2. Trot a circle around E, about 30" in diameter.
3. Stop where indicated. Move to off side.
4. Walk horse half way to D on off side. Trot the rest of the way to D on off side. Stop at D.
5. Return to near side. Turn 90-degrees on the right haunches. Walk to C.
6. Turn 90-degrees on the right forehand. Back three steps.
7. Side pass about three steps to the left. Trot serpentine through cones. Stop at A.
8. Move to off side and set up for inspection. After inspection, pick up any foot judge directs.
9. Exhibitor excused to line up.

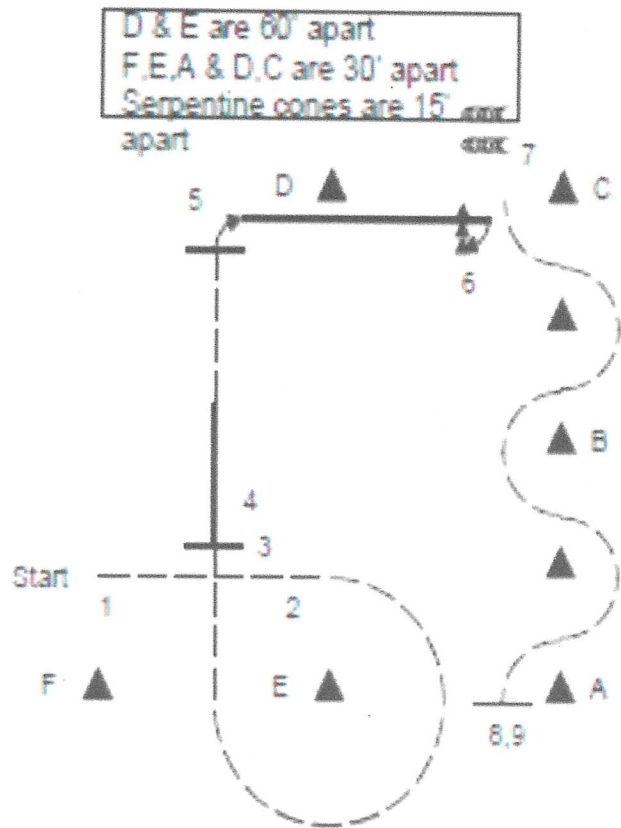

40

Rider # 329

Comments: hands about waistline

Very fluid. Well done

Point: YES NO

Judges Signature: [Signature]