





# Stockseat Equitation - Intermediates

High Blue = 100% - 92% (Enters Medal Program) Blue = 92% - 85% Red = 84% - 70% White = 70%-

#	Comments	Score	Danish	Placing
Chest/Blue 215	Heel ↓ Reins	86	B	<del>4</del> 3
<del>224</del>			—	—
Blk/White 225	Relax Sit back	84	R	5
Chest/Cream 206	Reins	86	B	2
Pal. 256		69	W	8
Bay/Blk 268		88	B	1
Grey 244	Leaning back legs under hips.	85	B	4
Bay 250	Keeps breaking gait.	73	R	7
Black 241	Sit deeper at lope	74	R	6

*PK*

# Stockseat Equitation - Seniors

High Blue = 100% - 92% (Enters Medal Program) Blue = 92% - 85% Red = 84% - 70% White = 70%-

#	Comments	Score	Danish	Placing
Dun 335	1 Purple little finger	85	B	4
2 Grey 364	+ Look up	87	B	3
3 Arab 343	Legs back a bit	88	B	2
Pal. 341	Gaming bit. wrong lead right	69	W	6
Apply 329	+ Nice	94 <del>84</del>	B	1
Bay 316	Scaffle - can 2 hand	73	R	5

pk

# Stock Seat Eq - Adults

Blue = 100% - 85%   Red = 84% - 70%   White = 69%-

#	Comments	Score	Danish	Placing
30				1
	PK			

STOCK SEAT

BRONZE MEDAL

PATTERN # 1

Start pattern at center rail

1. Lope from line on right lead.
2. Stop. Drop stirrups.
3. Jog a figure eight either direction.
4. Continue jogging and pick up stirrups.
5. Lope a figure eight plus a circle starting to the right showing two simple lead changes.
6. Stop.
7. Return to line at the jog.

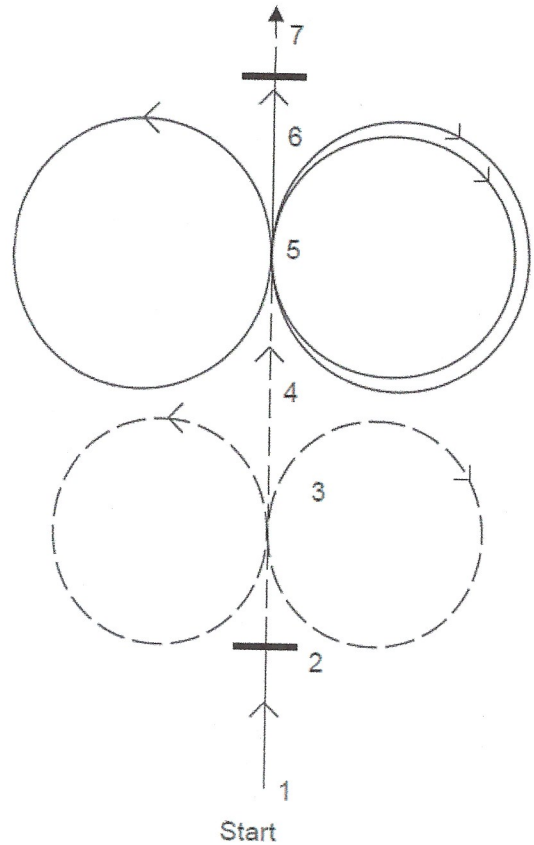

Rider # 343

Comments: Stop not immobile

Look up

Nice simple changes

Medal: YES NO

Judges Signature: PK

STOCK SEAT

SUPREME AWARD

PATTERN # 1

Start pattern on the rail. *hands slow*

1. Demonstrate a counter lope with a square stop.
2. Turn on hindquarters to the left.
3. Jog along rail and turn down center of arena.
4. Lope a figure eight plus a circle demonstrating two simple changes of lead. *1st S.C. fussy*
5. Continue figure eight plus a circle demonstrating two ~~flying~~ changes of lead. *2nd S.C.*
6. Lope out of figure eight and stop.
7. Turn on the forehand to the left.
8. Lope and stop.
9. Demonstrate two 180-degree haunch turns, first right then left. *1st S.C.*
10. Return to line at a jog.

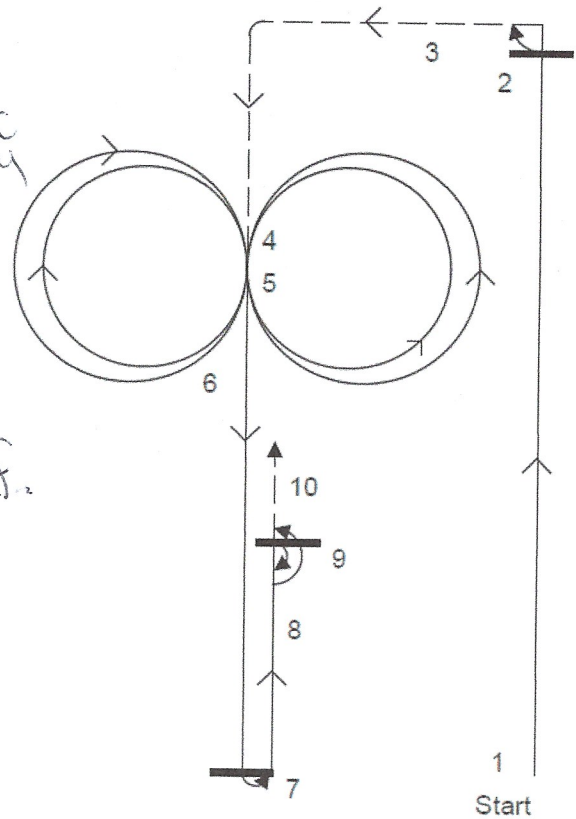

Rider # 329

Comments: \_\_\_\_\_  
\_\_\_\_\_  
\_\_\_\_\_  
\_\_\_\_\_

Point: YES

NO

Judges Signature: PK