

Huntseat
Bareback Equitation - Juniors

High Blue = 100% - 92% (Enters Medal Program) Blue = 91% - 85% Red = 84% - 70% White = 69% -

| # | Comments | Score | Danish | Placing |
|----------------|------------------------------|-------|--------|---------|
| 116 | Baw | | | |
| 109 | Wrong diagonal when reversed | 83 | R | |
| 105 | Red Ribbon | | | |
| 105 | work on eq. | 90 | B | |
| 125 | | | | |
| 125 | | | | |
| 131 | | | | |
| 131 | | | | |
| | | | | |
| | | | | |
| | | | | |
| | | | | |
| | | | | |
| | | | | |
| | | | | |
| | | | | |
| | | | | |
| | | | | |
| | | | | |
| | | | | |
| | | | | |
| | | | | |
| | | | | |

Huntseat Equitation - Seniors

High Blue = 100% - 92% (Enters Medal Program) Blue = 91% - 85% Red = 84% - 70% White = 69%-

| # | Comments | Score | Danish | Placing |
|-------------------|----------|-------|-----------|-----------------|
| Ch 302 | ++ wh | 83 | R | 4 th |
| c+w 320 | | 82 | R | 5 th |
| Red Ribbon 335 | + | 88 | B | 3 rd |
| Bay 339 | wh | 68 | W | 6 th |
| Blk 305 | | 90 | B | 2 nd |
| 343 | | | | |
| Gray 364 | ++ | 95 | High B | 1 st |
| | | | | |
| | | | | |
| | | | | |
| | | | | |

HUNT SEAT FLAT

BRONZE MEDAL

PATTERN # 3

Start pattern at the rail

1. Hand gallop down the rail, around the end of the arena, and turn down center.
2. 1/4 ways down the center, halt (4-6 seconds) and back three steps.
3. Pick up left lead and canter a figure eight demonstrating one simple change of lead.
4. Trot a figure eight with one change of diagonal.
5. Trot out of figure eight and return to line.

302

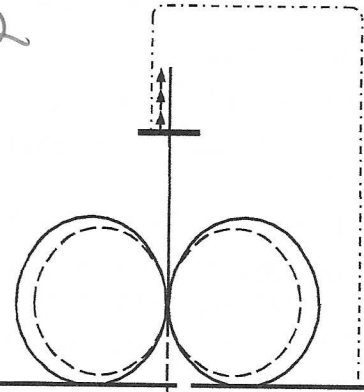

Rough start, not enough back steps
wrong leg in one circle

No

HUNT SEAT FLAT

BRONZE MEDAL

PATTERN # 4

Start pattern at center rail.

1. Walk from line and turn right to the rail.
2. Transition to canter and increase speed to hand gallop.
3. Turn left and transition to trot.
4. At mid rail, turn left and continue trotting to center of eight.
5. Halt (4-6 seconds).
6. Trot a figure eight showing one diagonal change. Halt.
7. Canter a figure eight showing one simple change of lead.
8. Trot out of figure eight.
9. Halt. Back four steps then step forward. Halt
10. Return to line at the walk.

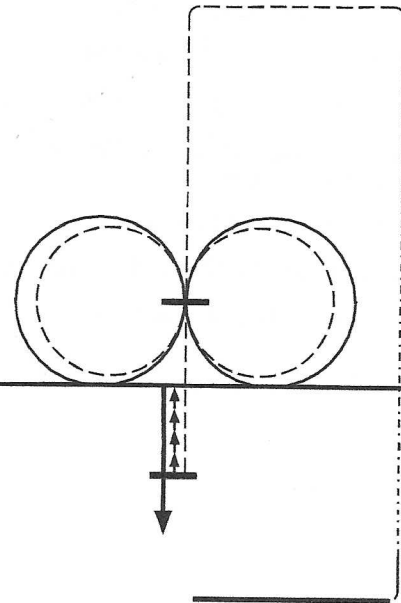

Start pattern at the rail

1. Hand gallop down the rail, around the end of the arena, and turn down center.
2. 1/4 ways down the center, halt (4-6 seconds) and back three steps.
3. Pick up left lead and canter a figure eight demonstrating one simple change of lead.
4. Trot a figure eight with one change of diagonal.
5. Trot out of figure eight and return to line.

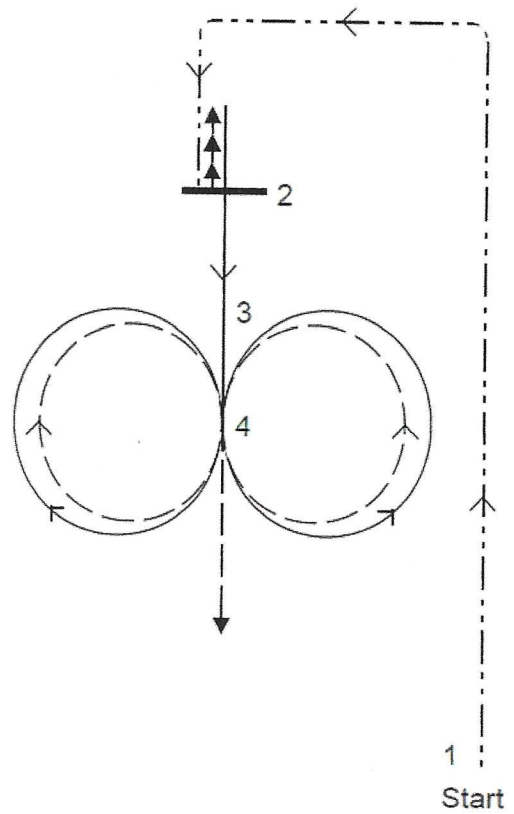

Rider # 116

Comments: More of a hand gallop. Break in gait
with canter circles. Wrong diagonal in circle

Medal Awarded: YES NO

[Signature]
 Judge's Signature

HUNT SEAT FLAT

SILVER MEDAL

PATTERN # 3

Start pattern at center rail

1. Trot a figure eight showing one change of diagonal. Halt.
2. Trot a serpentine with two diagonal changes.
3. Canter a serpentine with two simple lead changes,
4. Canter a figure eight with one simple or flying lead change.
5. Continue out of eight and turn right.
6. At corner increase speed to a hand gallop.
7. Pull up and halt (4-6 seconds). Back three steps.
8. Execute a 180-degree turn on the forehand to the left. Drop stirrups and pick up a trot.
9. Stop. Pick up stirrups. Return to line at the walk.

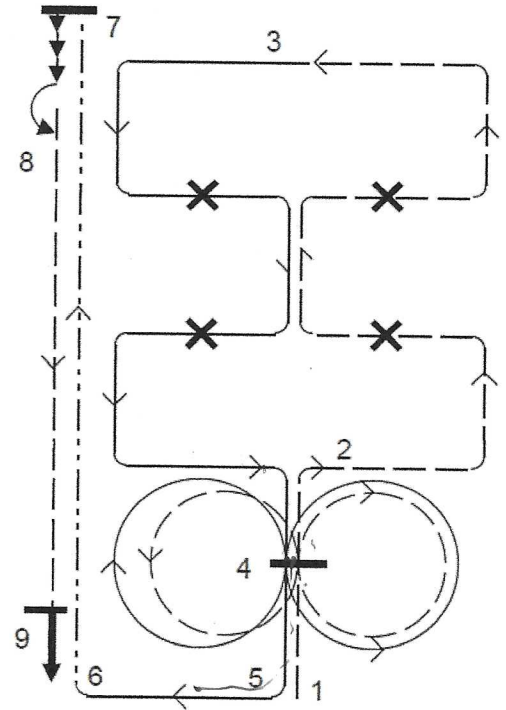

Rider # 335

Comments: Missed the right bend

Medal Awarded: YES

NO

[Signature]
 Judge's Signature

Start pattern at the rail

1. Hand gallop down the rail, around the end of the arena, and turn down center.
2. 1/4 ways down the center, halt (4-6 seconds) and back three steps.
3. Pick up left lead and canter a figure eight demonstrating one simple change of lead.
4. Trot a figure eight with one change of diagonal.
5. Trot out of figure eight and return to line.

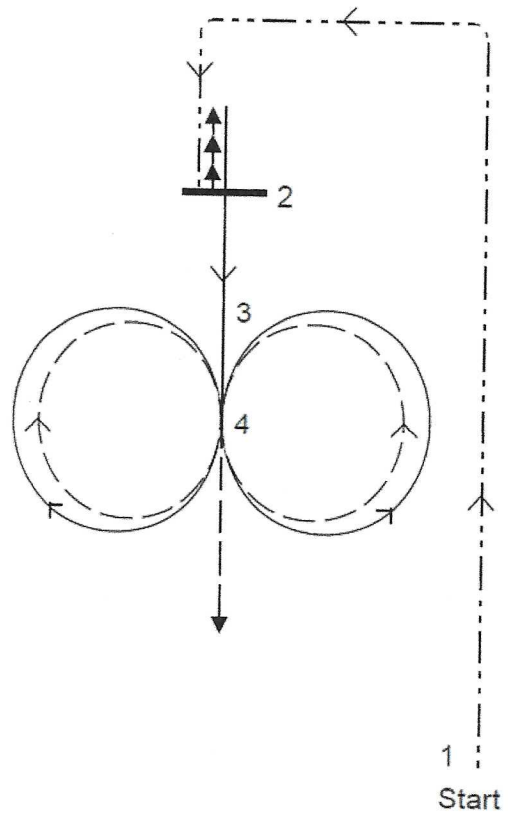

Rider # 235

Comments: back / longer halt hold

Medal Awarded: YES NO

[Signature]
Judge's Signature

HUNT SEAT FLAT

BRONZE MEDAL

PATTERN # 3

Start pattern at the rail

1. Hand gallop down the rail, around the end of the arena, and turn down center.
2. 1/4 ways down the center, halt (4-6 seconds) and back three steps.
3. Pick up left lead and canter a figure eight demonstrating one simple change of lead.
4. Trot a figure eight with one change of diagonal.
5. Trot out of figure eight and return to line.

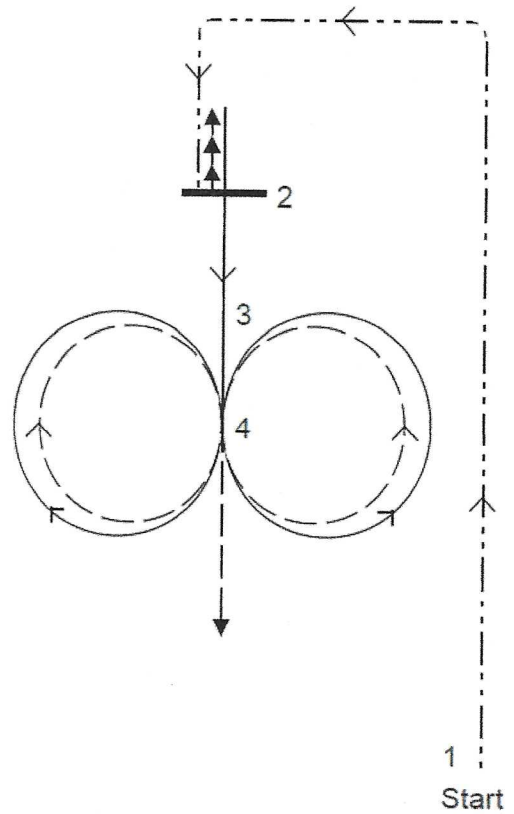

Rider # ~~105~~ 105

Comments: _____

Medal Awarded: YES NO

OH

Judge's Signature

HUNT SEAT FLAT

BRONZE MEDAL

PATTERN # 3

Start pattern at the rail

1. Hand gallop down the rail, around the end of the arena, and turn down center.
2. 1/4 ways down the center, halt (4-6 seconds) and back three steps.
3. Pick up left lead and canter a figure eight demonstrating one simple change of lead.
4. Trot a figure eight with one change of diagonal.
5. Trot out of figure eight and return to line.

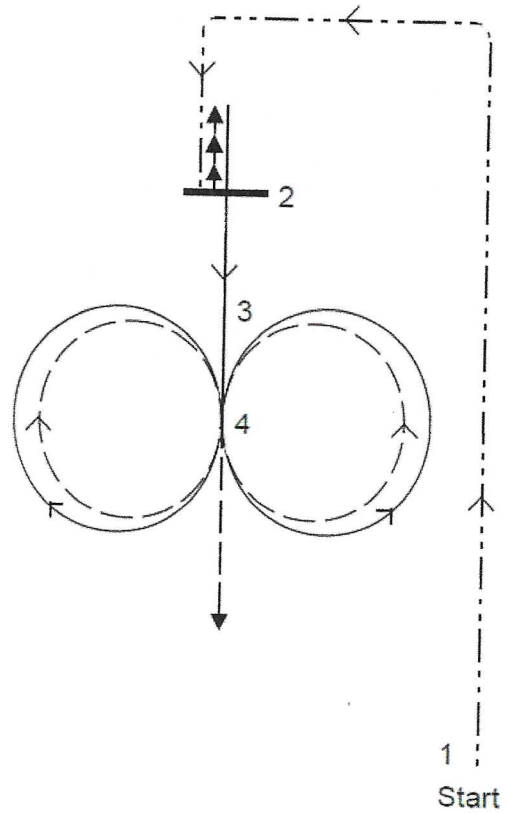

Rider # 2060

Comments: More back needed

Medal Awarded: YES NO

[Signature]
Judge's Signature

Name: Kylie Kaslik

Back Number: 364

Medal: Gold

Date: _____



1. Begin at the start point
2. At a posting trot on the right diagonal, trot down the centerline of the arena.
3. $\frac{1}{4}$ of the way down centerline, execute one change of diagonal.
4. At the midpoint of the arena, halt.
5. Perform a 90° forehand turn to the left.
6. On the right lead, canter to the right.
7. At the far end of the arena make 2 full figure eights completing 3 flying changes, total.
8. Once to the far wall, drop stirrups and hand gallop from the back side of the arena to halfway down the left wall.
9. Once halfway down the arena, halt for 4-6 seconds.
10. Back 4-6 steps.
11. Pick up stirrups and counter canter to the end of the arena.
12. Halt.
13. Canter on the left lead and serpentine 2 loops performing 1 simple change of lead.
14. Once to the wall, sit the trot and serpentine 2 loops to the opposite quarterline.
15. Proceed at the trot and halt near the end of the arena.
16. Continue at the trot, turn at the quarterline and half pass across the arena.
17. Proceed at the trot to the end of the arena. Then make a turn to the new quarter line.
18. Half pass across the arena.
19. Proceed at the trot.
20. Once to the end of the arena, halt.

yes

no

