

# King County 4-H Horse Project Medals Program Patterns and Guidelines



2023-2024 Edition



# Medals Program Patterns and Guidelines

## TABLE OF CONTENTS

page	
4	RULE CHANGE SUMMARY 2022-2023
4	RULE CHANGE SUMMARY 2019-2020
4	RULE CHANGE SUMMARY 2018-2019
4	RULE CHANGE SUMMARY 2016-2017
4	RULE CHANGE SUMMARY 2014-2016
5	RULE CHANGE SUMMARY 2013-2014
5	RULE CHANGE SUMMARY 2012-2013
5	RULE CHANGE SUMMARY 2011-2012
5	RULE CHANGE SUMMARY 2010-2011
6	RULE CHANGE SUMMARY 2009-2010
6	Program Overview
7	GENERAL RULES
7	Divisions of Competition
8	Qualification and Requirements
9	Conditions for holding qualifying classes
9	Conditions governing holding medals and medals qualifying classes
9	Judges qualifications
10	STOCK SEAT
11	Bronze Medal
13	Silver Medal
15	Gold Medal
16	Supreme Award
18	SADDLE SEAT
19	Bronze Medal
20	Silver Medal
23	Gold Medal
24	Supreme Award
26	HUNT SEAT FLAT
27	Bronze Medal
29	Silver Medal
31	Gold Medal
32	Supreme Award
34	SHOWMANSHIP
35	Bronze Medal
37	Silver Medal
39	Gold Medal
40	Supreme Award
42	TRAIL
42	Eligibility
42	Tests from which the judge must choose
42	Requirements for specific classes
43	REINSMANSHIP
43	Eligibility
44	Requirements for specific classes
45	Bronze
47	Silver
49	Gold
50	Supreme

52	HUNT SEAT OVER FENCES
53	Illustrations of fence types
54	Bronze Medal
58	Silver Medal
62	Gold Medal
66	Supreme Medal
70	DRESSAGE
72	WESTERN GAMES

*Only rule changes affecting Medals competition are included in this document. For complete lists of changes, please see the King County Horse Program Rule Book.*

### **Change Summary 2023-2024**

1. Process to qualify for and earn dressage medals has been changed to a google form and simplified
2. Amendment update from 2021: Dressage scores have been changed to:
  - a. Bronze 61% TLT2 and up
  - b. Silver 62% on TLT# and up
  - c. Gold 63% on FLT1 and up
  - d. Supreme 63% on FLT2 and up

### **Change Summary 2022-2023**

1. Points required to earn a Supreme Award are reduced to 3 points in all classes.
2. Juniors are now eligible to qualify for and earn medals.
3. The "24 hour" rule; where a member must wait 24 hours after qualifying for a medal to attempt their bronze medal is removed. Member may now try for their bronze at the same event as they qualified as long as the medals class happens after the qualification. No adjustment of the Bronze class in the schedule will be made to accommodate the new qualifiers attempt. Non King County 4-H events, requiring a letter of intent or State Fair, still require at least 24 hours between attempts.

### **Change Summary: 2019-2020**

1. By earning a showmanship medal in the medals program, will also earn you a danish blue in showmanship for that year.
2. The following has been added to medals program eligibility: The earning of 3 danish blues in a medals qualifying class will also earn you medals eligibility in that class, there is no time limit for earning blues. The earning of a high/return blue in a qualifying class will remain an additional means of earning medals eligibility in that class.

### **Change Summary: 2018-2019**

#### **administrative changes**

1. p6 remove: beginning section. Add Medals program is only open to Intermediates and Seniors. Those in the novice or green horse program are not eligible to qualify for or earn medals.
2. Line 3 remove statement in parentheses. Line 6: last several sentences change to: In Stock Seat, Hunt Seat, Saddle Seat, showmanship and Reinsmanship the pattern must last between 3 and 4 minutes. This does not include any questions asked by the judge. The medals committee shall provide a stopwatch for the timer for official timing. A designated timer must record each contestant's time.
3. P8 line C, 3: add: the show report and recap must be in the hands of the medals chair or permanent numbers chair within 5 days of the show or the club will pay a penalty of \$100 to the horse board. Line D, 6: remove: and/or original patterns are to be made by the judge or show management. E: remove. F: remove.
4. Jumping patterns will be updated in medals book and jump book.

### **Change Summary: 2017-2018 Year**

1. A reader will not be allowed for any dressage rider wishing to earn a medal.
2. Dressage medals will be earned by earning a 63% for Bronze, Silver or Gold. Supreme will be earned after the rider has earned a 63% on appropriate test 3 times, earning them 3 points. Additional supreme awards will be earned the same as the first, no advancement in test level is required.

### **Change Summary: 2016-2017**

1. A 4<sup>th</sup> pattern has been added to the Supreme medals program for Saddle Seat, Hunt Seat and Showmanship.
2. Saddle Seat Supreme #2 has been corrected to reflect appropriate lead changes.
3. The required percentage for trail medals has been removed to bring it more in line with how the other medals are awarded.
4. Dressage Medals percentages have been changed to: 65% in all levels.

#### **Administrative Changes:**

- Only if there is time for all medals to be offered for all disciplines will the Superintendent consider offering medals at fair or state qualifying event.
- The reference to judges using their own patterns for medals classes has been removed.
- References to double judging supreme classes has been removed.

### **Change Summary: 2014-2016 4-H Years**

1. Medals times for International Flags will be alters to better reflect current competitive times.
2. Saddle Seat lead changes will be changed to Interrupted lead changes.

3. Gaming and Dressage medals may be attempted at the State Qualifying Event and the State Fair without notifying the medals chair prior to the event. If the medals is earned the rider will pay the fee and receive the medal.
4. In jumping medals stride lengths will be shortened to be more accurate for the average horse.

**Change Summary: 2013-14 4-H Year**

1. The calendar for the following season will be decided upon by a committee chaired by the Medals Chair. This committee will consist of the performance and gaming committees, and a representative from any club that wishes to hold a show, judging or event during the next 4-H year. The committee wil present the completed calendar for the upcoming 4-H year by the last leaders meeting of the current 4-H year. Final calendar will be published by October 1<sup>st</sup> of the new 4-H year.
2. Remove the rule requiring 2 equitation or rail classes be held to offer medals classes.

**Change Summary: 2012-13 4-H Year**

1. After initial qualifying, riders may sign up for Medals attempts at dressage shows which offer Medals. A Medals class fee will be charged. Exhibitors will be allowed to have either of their qualifying tests count as medals attempts if the Medals fee has been paid prior to the tests being ridden.

**Change Summary: 2011-12 4-H Year**

1. The Medals program year will be concurrent with the 4-H program year and will run from October 1 through September 30. Qualified members may earn medals and Supreme points for as long as they are enrolled as youth members. If a member completes a Supreme award too late in the year for the award to be presented at the designated recognition event, he or she will still receive the award.

**Change Summary: 2010-11 4-H Year**

1. Fence heights in Over Fences classes are adjusted as follows to better align with height divisions offered at state fair and in surrounding counties:

Class	New Heights	Previous Heights
Regular (Qualifying)	2'3"-2'6"	2'-2'3"
Bronze	2'3"-2'6"	2'-2'3"
Silver	All fences 2'6"	2'3" - 2'6"
Gold	2'6" - 2'9"	All fences 2'6"
Supreme	All fences 2'9"	2'6" - 2'9"

2. Dressage Medal requirements are adjusted to reflect 2011 changes to USEF dressage tests. 2011 Training Level Test 3 replaces 2007 Training Level Test 4 as the minimum test for Silver. The minimum test required for a Gold medal changes from 2007 First Level Test 4 to 2011 First Level Test 1. The minimum test for a Supreme award changes from 2007 Second Level Test 4 to 2011 First Level Test 3. First Level Freestyle remains an option for a Supreme Award.

**ADMINISTRATIVE CHANGE:** The following language regarding Gold Medal patterns was added to section A.6. following the first sentence:

The pattern should be the member's original design. It should not be the same pattern as any pattern included in the Rules/Medals publications or posted before or at the show. By designing an original pattern, the member demonstrates an understanding of how elements are combined into patterns for the specific discipline and has an opportunity to showcase the particular strengths of the project horse which will demonstrate the pattern.

The first two sentences from the language above have also been added to the Gold Medal sections of the pages specific to Stock seat, Saddleseat, Hunt seat, Showmanship, Reinsmanship, and Over Fences.

### Change Summary: 2009-10 4-H Year

1. The overall percentage score required to earn a Supreme point in Trail changes from 75% to 90%.
2. An alternate set of over fences patterns (Open, Bronze, Silver, Gold, Supreme) that includes a combination jump has been added to the Rules and Medals books.
3. The dressage score ranges used for awarding Danish ribbons have been adjusted to provide a wider range for Red scores.
4. The minimum test that a dressage exhibitor must ride to earn a Bronze medal is changed from Training Level Test 1 to Training Level Test 2.

**ADMINISTRATIVE CHANGE:** The following change was made to align medals book and program with State Contest Guide. This change was approved by the King County Horse Program committee December 17, 2009.

***Effective March 1, 2010, participation in King County Medals programs is limited to Intermediate and Senior members.***

Additionally, language referring to the number of Bronze Medal competitors that should be selected to perform the pattern has been removed. This language reflected a period in the program when time constraints at shows did not allow all Bronze Medal contestants to perform the pattern. In recent years, all Bronze competitors have performed the pattern. The purpose of this change was to align rule book text with actual practice.

### MEDALS PROGRAMS OVERVIEW

Medal and Supreme Award competition has been formulated to offer an incentive to advanced riders encouraging them to further improve their horsemanship ability and knowledge. As of March 1, 2010, participation in King County Medals programs is **limited to Intermediate and Senior members**. Those in the Novice or Green Horse programs are not eligible to qualify for or earn medals. This change was made to align the King County Medals program with Pacific Northwest 4-H Horse Contest Guide.

Because regulation USEF and USDF dressage tests are used in 4-H competition, awards in the Dressage Medals program are based on achieving specified scores at specified test levels. Please refer to the Dressage section of this book for rules and guidelines relevant to dressage Medal competition and awards.

Please refer to the Western Games section of this book for rules and guidelines relevant to Western Games Medal competition and awards in running events.

Rules pertaining to Showmanship Medals found in the following General Rules sections apply to Showmanship Medal classes at all shows offering Showmanship (Performance, Gaming, Dressage, etc.).

## GENERAL RULES

### A. Divisions of Competition

There are four divisions of competition: Bronze, Silver, and Gold Medals and the Supreme Award. Medals competition is offered in Stock Seat, Saddle Seat, Hunt Seat Flat, Hunt Seat Over Fences, Showmanship, Trail, and Reinsmanship.

1. Classes may not be combined.
2. The pattern must be posted at least one hour before the class is held.
3. There shall be no minimum number of riders required to hold any medals class. It is the responsibility of the presiding judge to award the number of medals (if any) he/she feels is deserved. The decision of the judge is final.
4. All Medals contestants will perform the posted pattern.
5. In any medal class, if for any reason the judge changes the direction of the pattern, all contestants who have already ridden must be given an opportunity to reride. All contestants' responses are to be recorded by the ring steward, and once recorded there will be no further changes. If the choice is to re-ride, the re-ride will count. Every effort shall be made to ensure that all controllable conditions (i.e. lighting, location, and peripheral activities) will remain consistent throughout the entire medal class.
6. In Gold Medal classes, each contestant must prepare and provide at least two copies of the pattern he/she plans to demonstrate in writing, to be turned in for approval to the show office at time of registration. The pattern should be the member's original design. It should not be the same pattern as any pattern included in the Rules/Medals publications, other member's pattern or pattern posted before or at the show. By designing an original pattern, the member demonstrates an understanding of how elements are combined into patterns for the specific discipline and has an opportunity to showcase the particular strengths of the project horse which will demonstrate the pattern. The pattern must be checked by the Medals coordinator or his/her designee to verify that all elements are included. The approved pattern will be given to the judge prior to the class. In Stock Seat, Hunt Seat, Saddle Seat, and Reinsmanship, the ride must last between three and four minutes. If under three or over four minutes, the rider is disqualified. This does not include any questions asked by the judge. For Showmanship, the pattern should be three minutes. The medals committee shall provide a stopwatch for the timer for official timing. A designated timer must record each contestant's time.
7. The Supreme Award will be based on the following criteria:
  - a. Judge will select Supreme pattern from among the options in this book.
  - b. Each Supreme contestant will perform the selected pattern. Judge will award each rider one point or no point.
  - c. Contestants who are off course or who fail to perform the pattern correctly or to the standard expected of a Medals rider will receive no point. Judge's decision is final. (OFF COURSE: Failure of an exhibitor to complete any or all of the elements of a pattern in proper sequence. Example: a simple lead change is done where a flying lead change is required).
  - d. When a contestant has accumulated the following points, the Supreme Award will be presented:

Showmanship	3 points
Hunt seat flat:	3 points
Stock seat:	3 points
Trail	3 points
Saddle seat	3 points

Reinsmanship	3 points
Hunt seat fences	3 points
Dressage	3 points

Supreme awards will be selected annually by the Medals chair and a Supreme Awards Committee of at least three members.

- e. The Supreme Award may be won more than once.
  - f. The Supreme Award recipients will be presented their awards at the King County Fair or designated event in a manner deemed appropriate by the medals program Chairman and the King County Horse Committee. If for some reason a recipient cannot comply with this rule, he/she may petition in writing for an exception.
- B. Qualification and requirements for participation in Medal and Supreme Award competition:
1. Participation is limited to current Intermediate and Senior 4-H members enrolled in the King County 4-H Horse program.
  2. All riders must use their current year (Oct. 1-Sept. 30) project animal(s) in all qualification, Medal and Supreme Award classes. (PROJECT ANIMAL: Exhibitors must complete a current project/record book for each horse, and the animal must be declared as his/her project animal by the date of record each year.) Horse certificate must be on file by the date of record (April 1) for the horse and rider combination to be eligible.
  3. To qualify to enter Bronze medal competition an exhibitor must either:
    - a. Qualify for a championship equitation class by being awarded a high/return Blue Danish placing at King County Fair (or designated qualifying event) or the State 4-H Fair in Puyallup; or
    - b. Be awarded a high blue designation in a King County 4-H approved show in a class which has a Medals program. Horse show judges will be instructed to designate exhibitors who merit the high blue award. A high blue designation should be given to exhibitors who demonstrate the same high standard for a discipline which would be required to earn a high blue designation at the King County Fair or equivalent qualifying event. Show management will have the option to award actual high blue ribbons or to merely announce contestants who achieve a high blue designation; or
    - c. Earn 3 danish blue ribbons in a single medals qualifying class will earn the exhibitor a medals qualification in that class. These will have no time limit and will roll into the next year.
    - d. Qualifiers in Bareback will qualify in the seat in which they rode the Bareback class.
  4. The Medals Program Chairman will issue 4-H members who qualify for medals competition a qualification card when eligibility for bronze competition is established.
  5. Silver medal competition is open to bronze medal winners only.
  6. Gold medal competition is open to silver medal winners only.
  7. Supreme Award competition is open to gold medal winners only.
  8. When Silver, Gold, or Supreme Award eligibility is earned, the show secretary or medals chairman must endorse the qualification card.
  9. A contestant must show in the same seat in all divisions of Medal and Supreme Award competition. Example: The winning of a bronze medal in Stock Seat does not permit a contestant to show Hunt Seat in silver medal competition. No medal winner may compete in that division again in that seat with the exception of Supreme Award. Any queries as to eligibility are to be addressed to the medals chairman.
- C. Conditions for holding qualifying classes:



1. The Calendar for the following season will be decided upon by a committee chaired by the Medals Chair. This committee will consist of the performance and gaming committees, and a representative from any club that wishes to hold a show, judging or event during the next 4-H year. The committee will present the completed calendar for the following 4-H year by the last leaders meeting of the current 4-H year. Final calendar will be published by October 1<sup>st</sup> of the new 4-H year.
  2. The show must be announced on the horse program web site or at the horse program meeting one month prior to the date of the show.
  3. Show report and recap must be in the hands of the Medals Chair or Permanent Numbers Chair within 5 days of the show or pay a penalty of \$100 to the horse board.
  4. High blues in novice, junior or green horse classes will not qualify exhibitors for the medals program.
  5. A qualified judge is required to hold a qualifying class (see judging qualification in Section G.)
- D. Conditions governing Medals and Supreme Award competition:
1. In order to offer a 4-H Medal or Supreme Award class, a show must apply in writing to the medals program chairman for permission prior to publication of it's prize list.
    - a. It must be sponsored by a King County 4-H club.
  2. The show must be announced on the horse program web site or at the King County 4-H Horse Program meeting one month prior to the date of the show.
  3. Prize list must state compliance with medals program requirements.
  4. A qualified judge is required for Medals or Supreme classes.
  5. Show management must assure that the judge has in his/her possession current copies of the Pacific Northwest 4-H Horse Contest Guide and the King County 4-H Medals and Supreme Awards Rules and is familiar with the contents. Further, the judge will be contacted prior to the show by the medals committee chair or his/her designee to verify that all information has been received and understood by the judge.
  6. Patterns must be selected from those in the Medals book.
  7. A show must make a complete report of all medal recipients and supreme points awarded to the medals chairman within 5 days of the completion of the show or pay a \$100 fine to the horse board.
  8. Sponsoring club shall be responsible for the cost of the medals which may be obtained from the medals chairman. The entry fee of \$10 for each Supreme Award rider will also be paid to the chairman to cover the cost of the award.
  9. The Medals program year will be concurrent with the 4-H program year and will run from October 1 through September 30. Qualified members may earn medals and Supreme points for as long as they are enrolled as youth members. If a member completes a Supreme award too late in the year for the award to be presented at the designated recognition event, he or she will still receive the award.
- E. Judge's Qualifications
1. Minimum age shall be 21
  2. Must be a judge in good standing on the Pacific Northwest 4-H Horse Judges List or a judge in good standing on the Washington State Horseman's licensed officials list or be enrolled/licensed through the United States Equestrian Federation (USEF) as a learner judge or higher or have equivalent credentials as a breed association judge. Proof of eligibility may be requested.
  3. Shows wishing to hire individuals who do not hold any of the credentials listed in #2 may appeal to the 4-H Horse Program Committee for approval.

## STOCK SEAT MEDAL AND SUPREME AWARD COMPETITION

- A. Must comply with requirements stated in *Pacific Northwest 4-H Horse Contest Guide*, for Stock Seat Equitation.
- B. Judges must use a pattern from the four patterns provided for each level. Patterns must be posted at least one hour prior to the class.
  - 1. Bronze Medal Tests from pages 12 & 13
  - 2. Silver Medal Tests from pages 14 & 15
  - 3. Gold Medal: Each contestant shall perform a demonstration pattern of not less than three minutes nor more than four minutes. Contestants must prepare and provide at least two copies of the pattern he/she plans to demonstrate in writing, to be turned in for approval to the show office at time of registration. The pattern should be the member's original design. It should not be the same pattern as any pattern included in the Rules/Medals publications or posted before or at the show. The judge may ask for additional tests. See guidelines on page 16.
  - 4. Supreme Award Tests from pages 17 & 18. The judge will determine if the exhibitor's execution of the pattern merits the awarding of one Supreme point. When an exhibitor has accumulated three Supreme points in stock seat equitation, he or she will be eligible to receive a Stock Seat Supreme Award.

## STOCK SEAT

Start pattern at center rail

1. Lope from line on right lead.
2. Stop. Drop stirrups.
3. Jog a figure eight either direction.
4. Continue jogging and pick up stirrups.
5. Lope a figure eight plus a circle starting to the right showing two simple lead changes.
6. Stop.
7. Return to line at the jog.

## BRONZE MEDAL

### PATTERN # 1

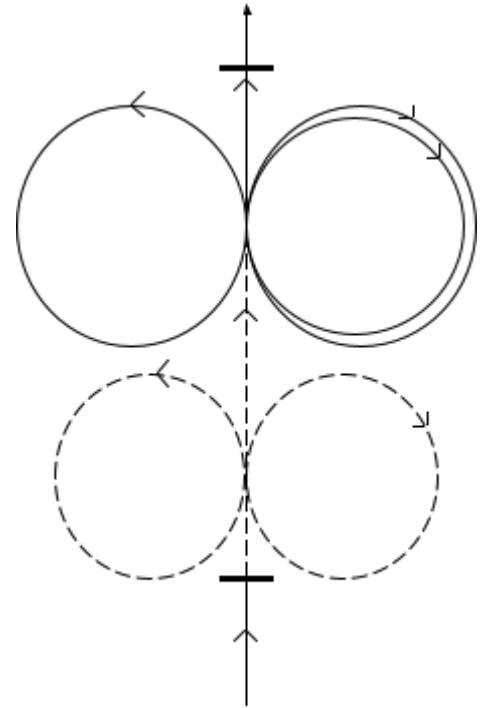

## STOCK SEAT

Start pattern on rail

1. Drop stirrups and jog.
2. Lope on left lead.
3. Stop and pick up stirrups.
4. Turn into center and lope a figure eight plus a circle starting to the right with two simple changes of lead.
5. Jog a figure eight.
6. Return to line at a jog.

## BRONZE MEDAL

### PATTERN # 2

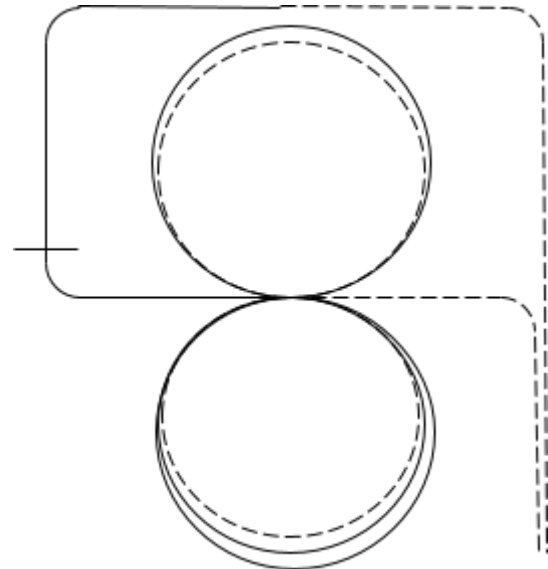

## STOCK SEAT

## BRONZE MEDAL

## PATTERN # 3

Start pattern at center rail

1. Jog.
2. Jog a figure eight in either direction. Continue jog to #3.
3. Pick up a lope on the right lead.
4. Lope a figure eight plus a circle with two simple lead changes.
5. Continue lope to #6
6. Stop.
7. Drop stirrups, pick up a lope, turn right, and lope down rail to far end of arena.
8. Stop. Return to line at the walk.

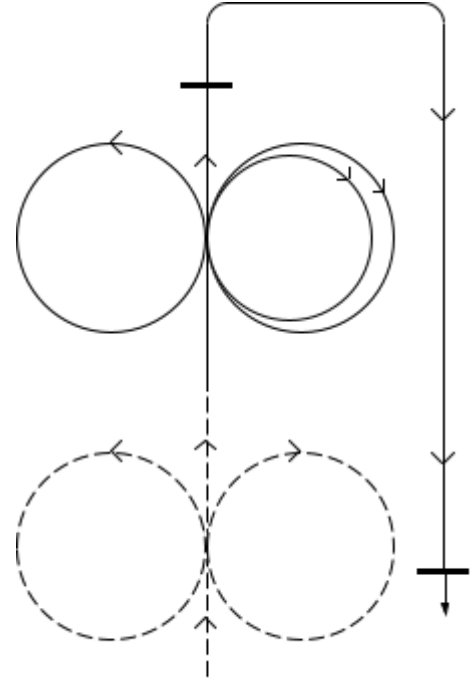

## STOCK SEAT

## BRONZE MEDAL

## PATTERN # 4

Start pattern on rail.

1. Begin at a jog up center of arena.
2. Jog a figure eight starting to the right.
3. Lope a figure eight plus a circle with two simple lead changes.
4. Continue lope in a straight line.
5. Stop 20 feet from end of arena. Drop stirrups.
6. Pick up a jog to end of arena, turn to the left (left track), and jog around corner and down the rail back to line.

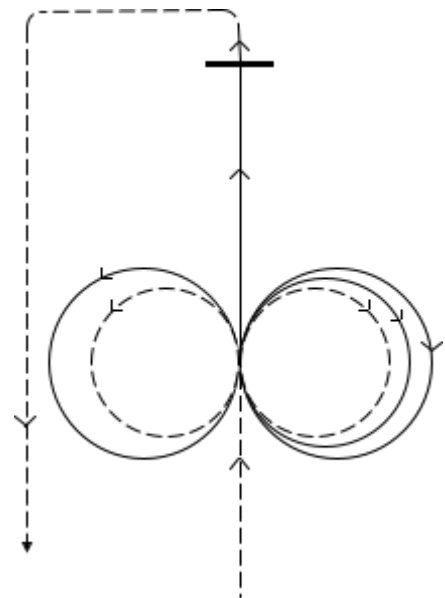

## STOCK SEAT

## SILVER MEDAL

1. Drop stirrups, lope to corner of arena.
2. Stop. Begin a lope on counter lead (right) to center point of arena.
3. Make transition to a jog, demonstrate a figure eight in either direction at a jog.
4. Jog out of figure eight and halfway to rail and turn to the right.
5. Begin a lope on right lead.
6. Demonstrate a figure eight plus a circle with two flying or simple lead changes.
7. Lope out of figure eight and stop. Pick up stirrups.
8. Back five steps. Walk forward.
9. Return to line at the jog.

## PATTERN # 1

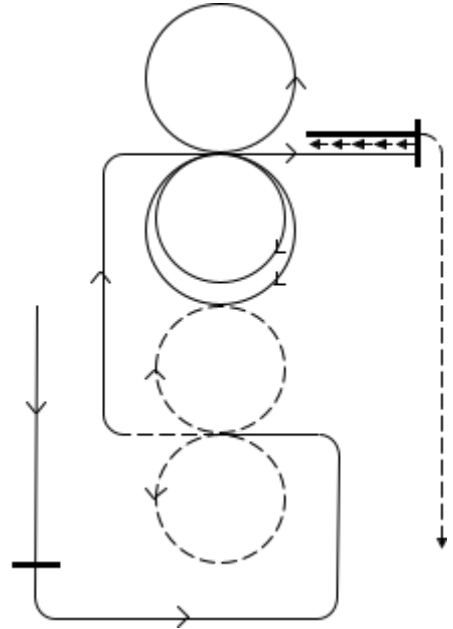

## STOCK SEAT

## SILVER MEDAL

1. Leave line at walk on right track.
2. At corner begin a lope on the right lead; lope diagonally across the arena.
3. At center do a simple lead change; continue across diagonal; at corner go left track on rail.
4. Halfway down rail transition to a jog; jog a figure eight. (1/2 circle to the left, full circle to the right, 1/2 circle to the left.)
5. Lope on left lead along the rail; at corner go diagonally to the center of arena.
6. Stop.
7. Walk to the rail.
8. At rail go right track; lope about three strides. Transition to extended jog around corner.
9. Stop. Return to line at a walk.

## PATTERN # 2

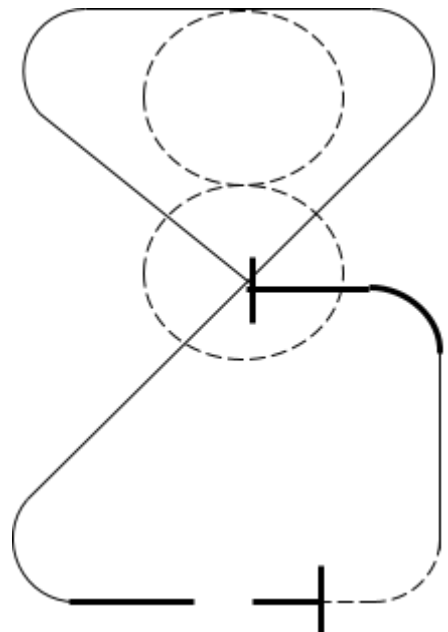

## STOCK SEAT

## SILVER MEDAL

## PATTERN # 3

1. Leave line at a walk, left track.
2. After corner do an extended jog diagonally to the center of the arena.
3. Stop, settle your horse.
4. Lope a figure eight plus a circle starting to the right showing two simple or flying lead changes.
5. Transition to a jog. Jog diagonally to the corner of the arena.
6. Jog around corner and turn down middle of the arena.
7. Jog a figure eight in either direction.
8. Lope down center of ring demonstrating two simple lead changes.
9. Stop. Return to line at a walk.

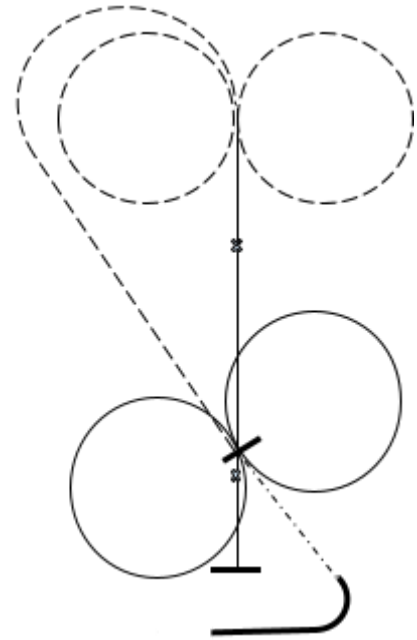

## STOCK SEAT

## SILVER MEDAL

## PATTERN # 4

1. Leave line without stirrups at a jog up center of arena.
2. At the center extend the jog.
3. Stop about 20 feet from rail; pick up stirrups.
4. Lope left track along the rail, around corner; half-way down arena, turn into center.
5. Stop. Back two steps.
6. Lope on left lead towards rail, demonstrate a simple change of lead and continue right track on the rail.
7. Halfway across the width of the arena transition to a jog.
8. Jog one third (1/3) of the length of the arena; curve into the center of the arena.
9. Jog a circle to the left
10. Lope in a straight line to your starting point.
11. Stop. Return to line at a walk.

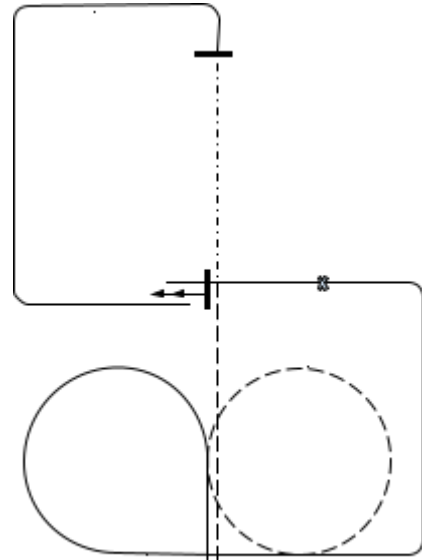

## STOCK SEAT GOLD MEDAL REQUIREMENTS

For Stock Seat, each contestant shall perform a demonstration pattern of not less than three minutes or more than four minutes. Pattern must include at least one item from each of the first five sets listed below. Tests may be performed in any order and may be repeated. Contestants must prepare and provide at least two copies of the pattern he/she plans to demonstrate in writing, to be turned in for approval to the show office at time of registration. The pattern should be the member's original design. It should not be the same pattern as any pattern included in the Rules/Medals publications or posted before or at the show. Medals coordinator or his/her designee shall verify that all elements are included. The judge may ask for additional tests.

### SET 1

- Figure eight (s) at a jog.
- Serpentine at a jog.

### SET 2

- Figure eight(s) at a lope demonstrating simple changes of lead.
- Serpentine at a lope demonstrating simple changes of lead.
- Lope down center of arena demonstrating simple lead change.

### SET 3

- Figure eight(s) at a lope demonstrating flying changes of lead.
- Serpentine at a lope demonstrating flying changes of lead.

### SET 4

- Execute 360-degree turn(s).
- Execute rollback(s).

### SET 5

- Demonstrate stop from lope
- Ride without stirrups
- Back up to eight steps

### SET 6 (OPTIONAL)

- Demonstrate a sliding stop.

---

Notes:

## STOCK SEAT

## SUPREME AWARD

## PATTERN # 1

Start pattern on the rail.

1. Demonstrate a counter lope with a square stop.
2. Turn on hindquarters to the left.
3. Jog along rail and turn down center of arena.
4. Lope a figure eight plus a circle demonstrating two simple changes of lead.
5. Continue figure eight plus a circle demonstrating two flying changes of lead.
6. Lope out of figure eight and stop.
7. Turn on the forehand to the left.
8. Lope and stop.
9. Demonstrate two 180-degree haunch turns, first right then left.
10. Return to line at a jog.

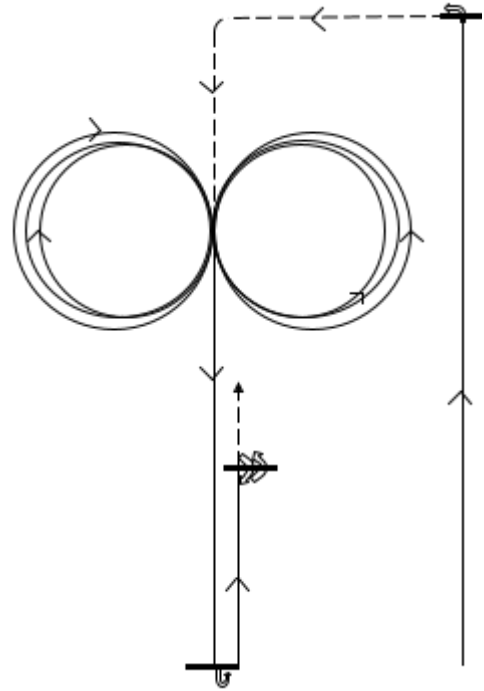

## STOCK SEAT

## SUPREME AWARD

## PATTERN # 2

Start pattern at center of rail.

1. Walk out of line, do a 90-degree haunch turn to right.
2. Lope a serpentine with three flying changes on the centerline. (Marked with "X" on drawing)
3. Stop. Do a 90-degree haunch turn to right.
4. Drop stirrups and extend jog to the center.
5. Lope a large circle to the left.
6. Jog a small circle to the right.
7. Jog a large circle to the right.
8. Lope a small circle to the left.
9. Transition to a walk, walk about 15 steps.
10. Stop. Return to line at a jog.

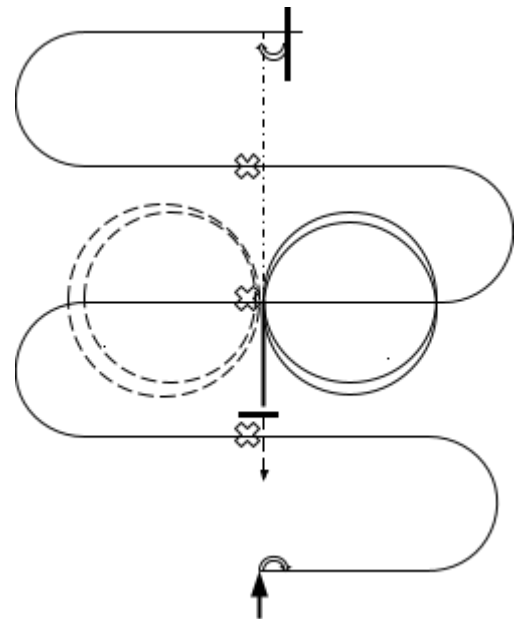



## STOCK SEAT

## SUPREME AWARD

Start pattern on rail

1. Extended lope past midway point of arena.
2. Stop. Back up to midway point. Settle horse.
3. Pivot horse 90-degrees left on haunch, lope into center of arena.
4. Lope small, slow figure eight then lope large, fast figure eight.
5. Turn right up center of arena and lope to rail.
6. Rollback to the left and lope down center of arena to opposite rail.
7. Rollback to the right and lope to center of arena.
8. Stop and settle horse. Return to line at a jog.

## PATTERN # 3

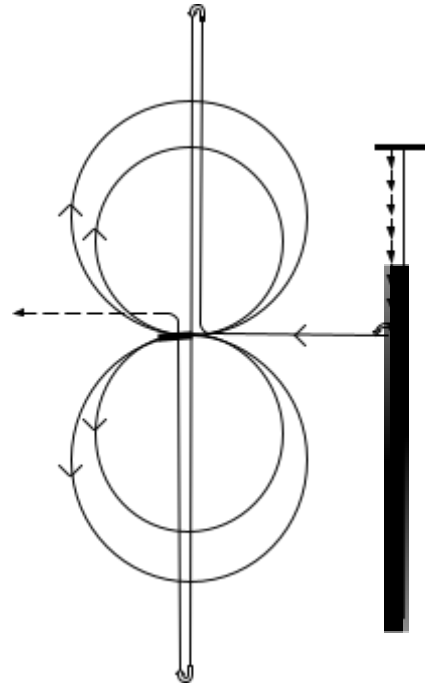

## STOCK SEAT

## SUPREME AWARD

Start pattern on rail.

1. Beginning on left lead, lope to end of ring showing two simple changes.
2. Continue at a lope around ring to cones and lope showing flying changes.
3. Stop. Drop stirrups, jog a figure eight.
4. Jog out of figure eight and stop.
5. Perform a 360-degree turn to the right, a 360-degree turn to the left, continue 90-degrees further to the left. Side pass three steps to the right.
6. Back to rail and turn 90-degrees to the left on the forehand.
7. Pick up stirrups. Lope on right lead.
8. Halt. Return to line at a jog.

## PATTERN # 4

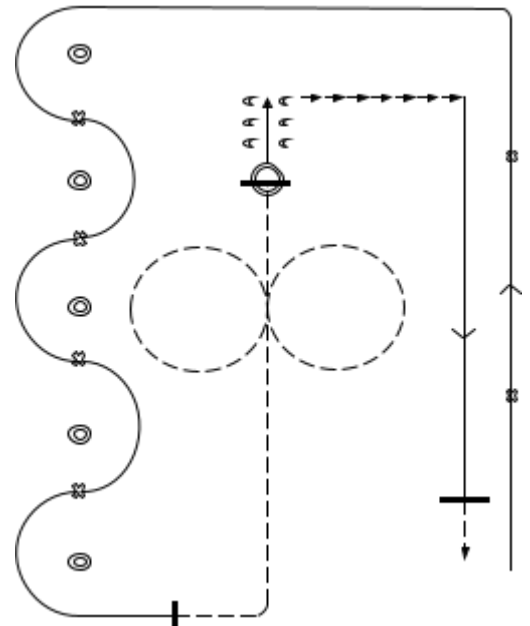

## SADDLE SEAT MEDAL AND SUPREME AWARD COMPETITION

- A. Must comply with requirements stated in *Pacific Northwest 4-H Horse Contest Guide*, for Saddle Seat Equitation.
- B. Judges may use one of the the four patterns provided for each level. Patterns must be posted at least one hour prior to the class.
- Bronze Medal: Pattern from pages 19 & 20.
  - Silver Medal: Pattern from pages 21 & 22.
  - Gold Medal: Each contestant shall perform a demonstration pattern of not less than three minutes nor more than four minutes. Contestants must prepare and provide at least two copies of the pattern he/she plans to demonstrate in writing, to be turned in for approval to the show office at time of registration. The pattern should be the member's original design. It should not be the same pattern as any pattern included in the Rules/Medals publications or posted before or at the show. The judge may ask for additional tests.
  - Supreme Award: Pattern from pages 24 & 25. The judge will determine if the exhibitor's execution of the pattern merits the awarding of one Supreme point. When an exhibitor has accumulated three Supreme points in saddle seat equitation, he or she will be eligible to receive a Saddle Seat Supreme Award.

## SADDLE SEAT

## BRONZE MEDAL

## PATTERN # 1

Start pattern at center rail

1. Walk out of line.
2. Stop and disengage irons.
3. When acknowledged by the judge, re-engage stirrups and address the reins.
4. Trot forward on left diagonal.
5. Begin a figure eight to the right demonstrating a diagonal change.
6. Trot out of figure eight. At end of arena turn left around corner and trot down far rail to opposite end.
7. Stop. Back five steps.
8. Trot back to line on right diagonal.

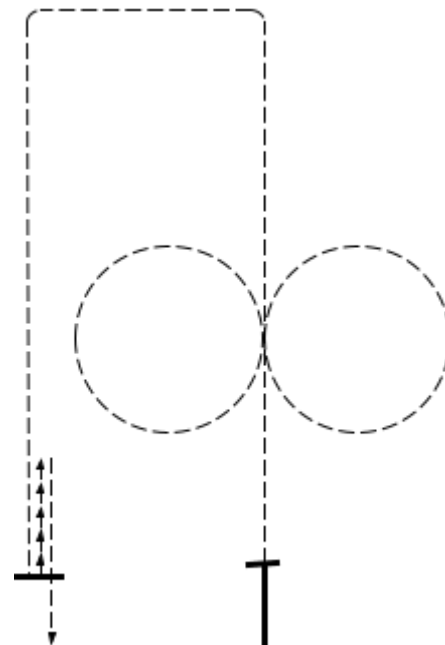

## SADDLE SEAT

## BRONZE MEDAL

## PATTERN # 2

Start pattern in line.

1. Address reins.
2. Back eight steps out of line.
3. Turn right on hindquarters, on correct lead, canter to rail and down rail to mid point.
4. Transition to a trot to center of far end rail and turn down center.
5. Trot to center of arena; demonstrate a figure eight beginning to the right showing one change of diagonal.
6. Stop. Return to line at a trot.

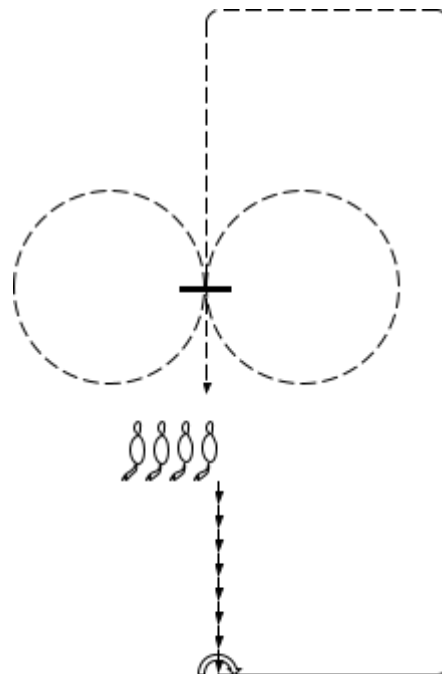

## SADDLE SEAT

## BRONZE MEDAL

## PATTERN # 3

Start pattern at center rail

1. Trot on right diagonal.
2. Begin a figure eight to the right, demonstrating one diagonal change.
3. Trot up center line turning to the left at end of arena, trot down rail to halfway point.
4. Stop. Back four steps.
5. Reverse horse in hindquarters and trot around far end of arena.
6. Stop. Address reins.
7. Return to the line at a trot

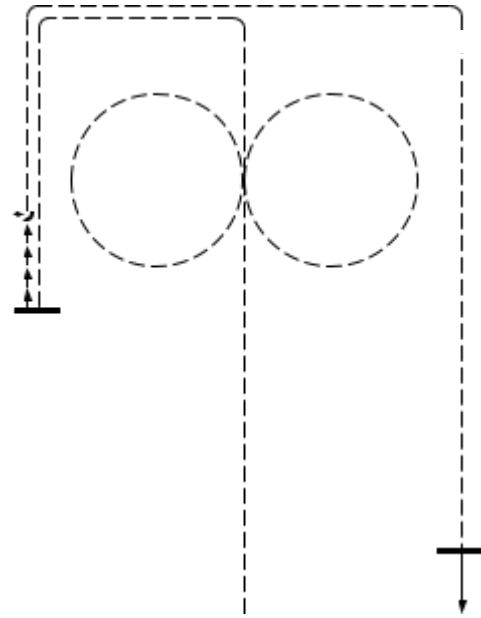

## SADDLE SEAT

## BRONZE MEDAL

## PATTERN # 4

Start pattern on rail.

1. Disengage and engage stirrups at the direction of the judge.
2. Canter down rail on correct lead.
3. Trot a circle.
4. Trot out of circle on the rail to the left.
5. Trot down rail showing two diagonal changes, marked with asterisks.
6. Stop. Back horse three steps.
7. Return to line at a walk.

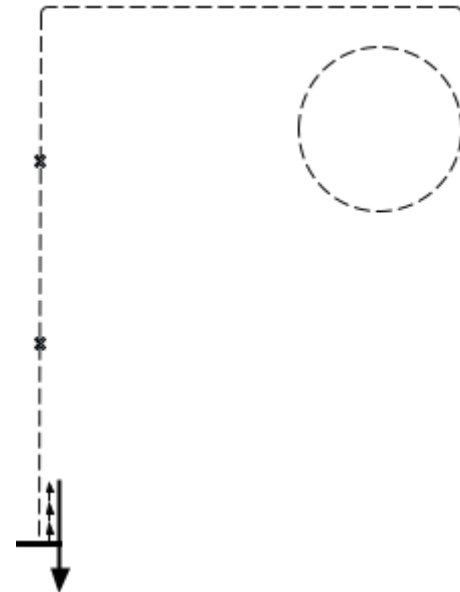

## SADDLE SEAT

## SILVER MEDAL

## PATTERN # 1

Start pattern at center rail

1. Trot from line into a figure eight to the right demonstrating one diagonal change.
2. Continue trotting up center line 20-30 feet.
3. Stop. Back horse five steps.
4. Pick up a canter on right lead.
5. Begin a figure eight to the right demonstrating one interrupted lead change.
6. Continue cantering on left lead around corner of arena to left staying approximately 10 feet off the rail.
7. Demonstrate an interrupted lead change.
8. Stop. Return to line at a trot.

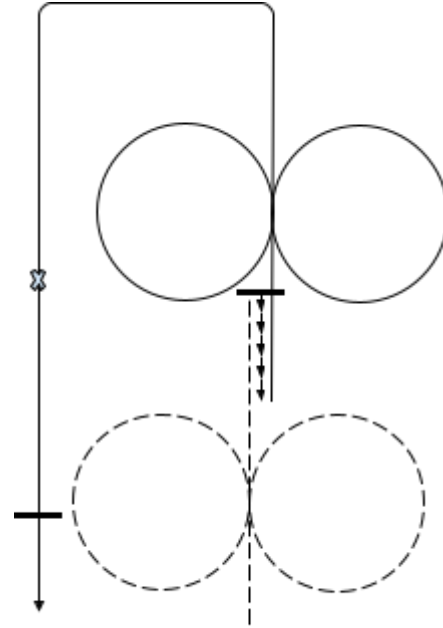

## SADDLE SEAT

## SILVER MEDAL

## PATTERN # 2

Start pattern at center rail

1. Trot out of line.
2. Stop. Address reins
3. Trot left beginning a serpentine using the left half of the arena showing three diagonal changes.
4. Stop facing the far end of arena where you begin your figure eight.
5. Execute one figure eight at the canter showing one interrupted lead change.
6. Stop. Back four steps.
7. Trot to rail using either side of arena and show your horse at an extended trot with collection.
8. Stop. Return to line at a trot.

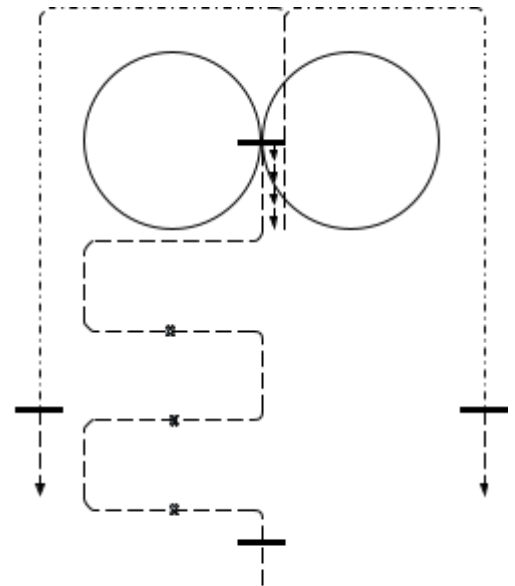

## SADDLE SEAT

## SILVER MEDAL

Start pattern at center rail

1. Leave the line at walk; turn 1/4 to the right.
2. Canter a serpentine with three interrupted lead changes.
3. Stop. Turn 1/4 turn to right.
4. Trot down center demonstrating two diagonal changes.
5. Trot a figure eight with one change of diagonal.
6. Canter a figure eight with one interrupted lead change.
7. Stop. Back five steps.
8. Walk forward to judge.
9. Stop. Address reins.
10. Return to line at a walk.

## PATTERN # 3

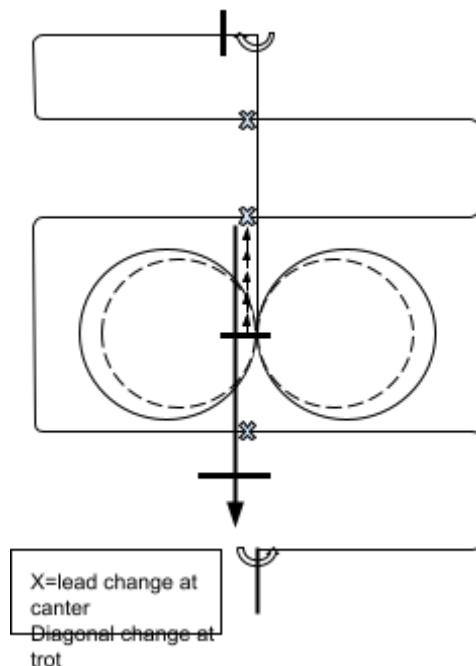

## SADDLE SEAT

## SILVER MEDAL

Start pattern at center rail

1. Begin cantering up center of arena on right lead.
2. Canter a figure eight demonstrating a interrupted lead change.
3. Transition to a trot. Trot a figure eight demonstrating one diagonal change.
4. Trot out of figure eight to far end of arena and turn left to corner.
5. Stop. Turn left and begin a canter across diagonal of arena on left lead to halfway point of opposite rail.
6. Stop. Turn right and begin a canter across diagonal of arena on left lead to corner.
7. Stop. Turn left and walk to center rail
8. Stop. Disengage and engage feet at the direction of the judge.
9. Return to line at a walk.

## PATTERN # 4

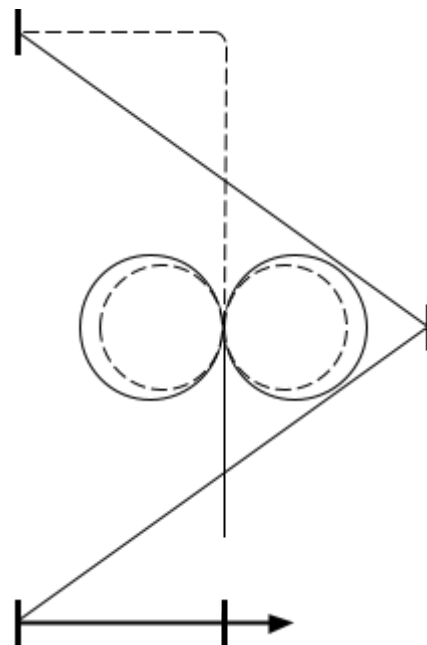

## SADDLE SEAT GOLD MEDAL REQUIREMENTS

For Saddle Seat, each contestant shall perform a demonstration pattern of not less than three minutes or more than four minutes. Pattern must include at least one item from each of the first four sets listed below. Tests may be performed in any order and may be repeated. Contestants must prepare and provide at least two copies of the pattern he/she plans to demonstrate in writing, to be turned in for approval to the show office at time of registration. The pattern should be the member's original design. It should not be the same pattern as any pattern included in the Rules/Medals publications or posted before or at the show. Medals coordinator or his/her designee shall verify that all elements are included. The judge may ask for additional tests.

### SET 1

- Pick up reins (address reins).
- Back up to eight steps.
- Feet disengaged from stirrups. Feet engaged; at halt only.

### SET 2

- Figure eight(s) at a trot, demonstrating change of diagonals.
- Serpentine at a trot demonstrating change of diagonals.
- Trot down center of arena or down rail demonstrating change of diagonals.

### SET 3

- Figure eight(s) at a canter demonstrating interrupted lead change(s).
- Serpentine at a canter demonstrating interrupted lead change(s).
- Canter down center of arena demonstrating interrupted lead change(s).

### SET 4

- Ride without irons at a trot for not more than one minute\*.
  - Ride without irons at a canter\*.
- \*Drop irons at a halt, pick up at halt or walk.

### SET 5 (OPTIONAL)

- Circle at a trot.
- Circle at a canter on the correct lead.

---

Notes:

## SADDLE SEAT

## SUPREME AWARD

## PATTERN # 1

Start on center rail.

1. Take left track on the rail demonstrating a collected sitting trot
2. At first corner beginning normal trot, posting to far end of ring, demonstrating two changes of diagonal.
3. Curve towards the middle to where you will begin a figure eight.
4. Stop. Demonstrate a "sandwich\*" figure eight with correct leads and diagonals. \*Trot circle to right, stop. Canter circle to left, stop. Canter circle to right, stop. Trot circle to left, stop.
5. Stop. Back four steps, address reins, drop stirrup irons.
6. Trot down middle of ring towards line, using either diagonal.
7. Stop. Pick up stirrup irons. Return to line at a walk.

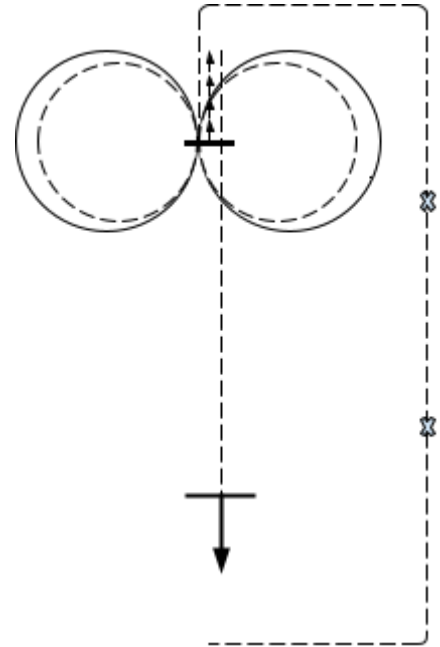

## SADDLE SEAT

## SUPREME AWARD

## PATTERN # 2

Start at center of rail.

1. Beginning up center of ring, trot four steps, right diagonal.
2. Canter four strides, left lead.
3. Walk four strides, then canter four strides, right lead.
4. Trot four strides left diagonal.
5. Stop where you will begin a figure eight. Turn 180-degrees on the forehand either direction.
6. Address reins then drop stirrup irons.
7. Trot one figure eight, showing one diagonal change.
8. Stop at center of figure eight, pick up stirrup irons. Back four steps; stop.
9. Trot towards starting point, in center of ring, using either diagonal.
10. Stop, return to line at a walk.

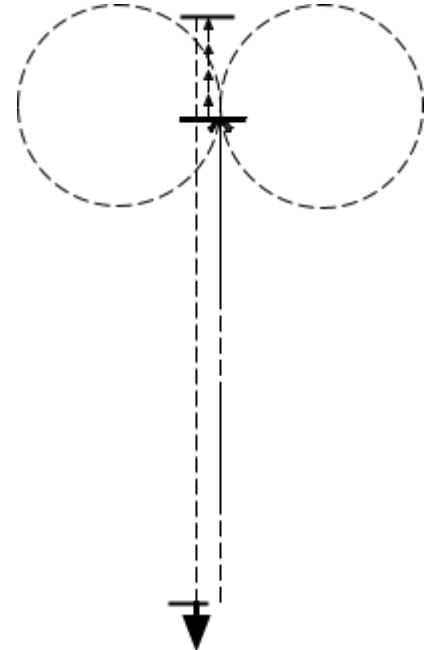



## SADDLE SEAT

## SUPREME AWARD

## PATTERN # 3

Demonstrate a diamond pattern starting on center

1. Beginning to the right, trot on the left diagonal across to halfway point of rail showing one change of diagonal.
2. Stop. Canter a circle on right lead. Canter out of circle 10 feet, then demonstrate interrupted lead change. Continue to halfway point of rail.
3. Stop. Turn left and begin a trot on the right diagonal to halfway point of rail showing one change of diagonal.
4. Stop. Canter a circle on the left lead. Continue out of circle to halfway point of rail.
5. Stop. Execute a serpentine at a canter, demonstrating three interrupted lead changes.
6. Stop. Drop stirrups. Turn 90-degrees on forehand and trot down center of arena.
7. Stop. Pick up stirrups and return to line at a walk.

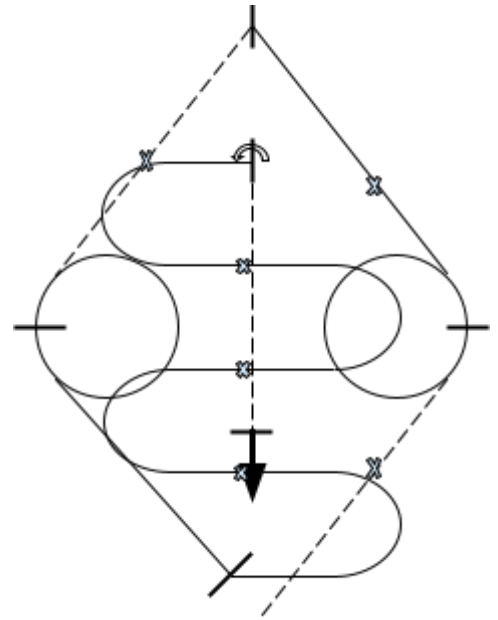

## SADDLE SEAT

## SUPREME AWARD

## PATTERN # 4

1. Pick up a trot, trot a circle to the left.
2. Trot to next rail, changing diagonal, trot a circle to the right.
3. Trot to next rail, changing diagonal, trot a circle to the left.
4. Trot to next rail, changing diagonal, trot a circle to the right.
5. Drop to a walk and walk to corner.
6. Pick up canter.
7. Canter a serpentine showing interrupted lead changes.
8. Canter down center and halt.
9. Back 4 steps, close your back and address reins.

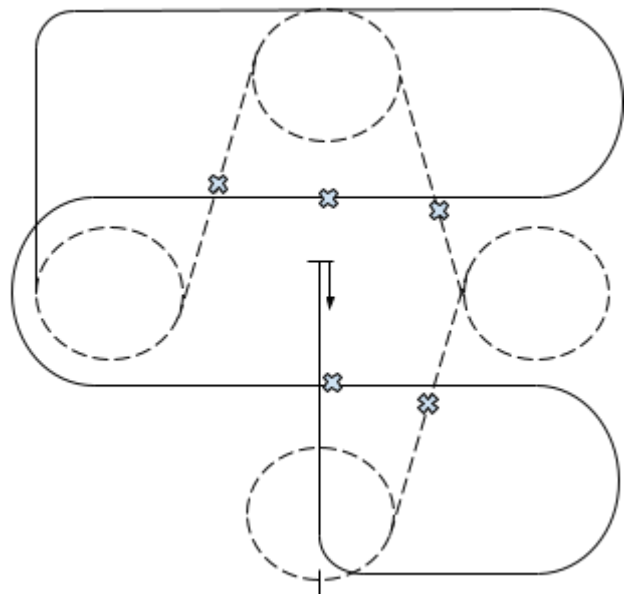

## HUNT SEAT FLAT MEDAL AND SUPREME AWARD COMPETITION

- A. Must comply with requirements stated in *Pacific Northwest 4-H Horse Contest Guide*, for Hunt Seat/Hunt Seat Over Fences Equitation.
- B. Judges may use a pattern from the four patterns provided for each level. Patterns must be posted at least one hour prior to the class.
  - 1. Bronze Medal: Pattern from pages 27 & 28
  - 2. Silver Medal: Pattern from pages 29 & 30
  - 3. Gold Medal: Each contestant shall perform a demonstration pattern of not less than three minutes nor more than four minutes. Contestants must prepare and provide at least two copies of the pattern he/she plans to demonstrate in writing, to be turned in for approval to the show office at time of registration. The pattern should be the member's original design. It should not be the same pattern as any pattern included in the Rules/Medals publications or posted before or at the show. The judge may ask for additional tests.
  - 4. Supreme Award: Pattern from pages 32 & 33. The judge will determine if the exhibitor's execution of the pattern merits the awarding of one Supreme point. When an exhibitor has accumulated three Supreme points in hunt seat equitation on the flat, he or she will be eligible to receive a Hunt Seat Supreme Award.

## HUNT SEAT FLAT

## BRONZE MEDAL

Start pattern at rail

1. Canter from line on right lead.
2. Demonstrate a figure eight with one simple change of lead.
3. Continue cantering up center of arena.
4. Transition to a trot; demonstrate one figure eight at the trot showing change of diagonal.
5. Continue trotting out of figure eight.
6. Transition to a canter, at end of arena; turn left.
7. Increase speed of canter to a hand gallop.
8. Pull up and halt (4-6 seconds) then back five steps.
9. Return to line at the walk.

## PATTERN # 1

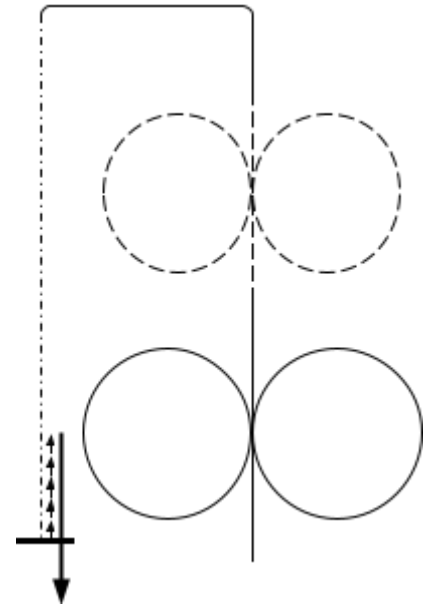

## HUNT SEAT FLAT

## BRONZE MEDAL

Start pattern at center of rail.

1. Trot a figure eight showing one diagonal change.
2. Canter a figure eight demonstrating one simple change of lead.
3. Hand gallop up center and halt (4-6 seconds).
4. Back six steps then step forward.
5. Return to line at the trot.

## PATTERN # 2

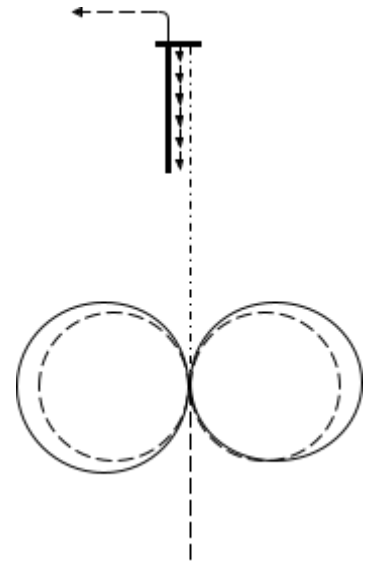

## HUNT SEAT FLAT

## BRONZE MEDAL

## PATTERN # 3

Start pattern at the rail

1. Hand gallop down the rail, around the end of the arena, and turn down center.
2. 1/4 ways down the center, halt (4-6 seconds) and back three steps.
3. Pick up left lead and canter a figure eight demonstrating one simple change of lead.
4. Trot a figure eight with one change of diagonal.
5. Trot out of figure eight and return to line.

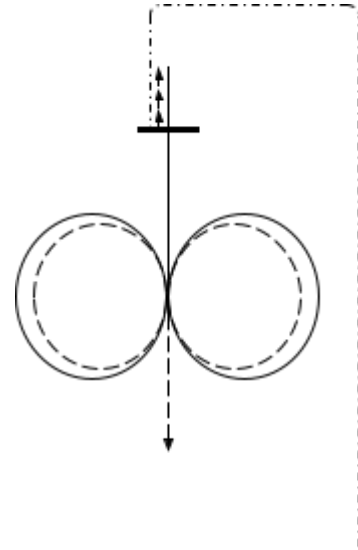

## HUNT SEAT FLAT

## BRONZE MEDAL

## PATTERN # 4

Start pattern at center rail.

1. Walk from line and turn right to the rail.
2. Transition to canter and increase speed to hand gallop.
3. Turn left and transition to trot.
4. At mid rail, turn left and continue trotting to center of eight.
5. Halt (4-6 seconds).
6. Trot a figure eight showing one diagonal change. Halt.
7. Canter a figure eight showing one simple change of lead.
8. Trot out of figure eight.
9. Halt. Back four steps then step forward. Halt
10. Return to line at the walk.

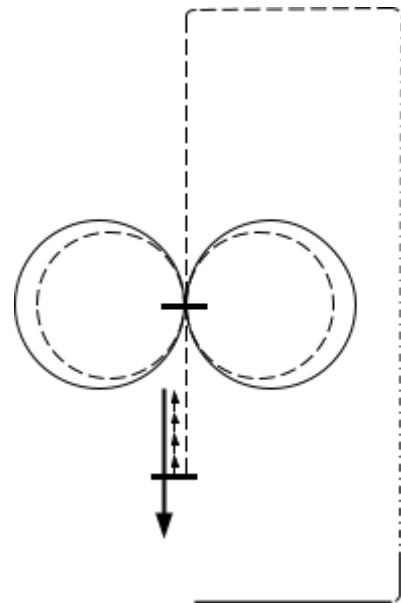

## HUNT SEAT FLAT

## SILVER MEDAL

Start pattern at rail

1. Canter a serpentine with two simple lead changes.
2. Continue canter around end of arena and increase speed to hand gallop.
3. Pull up and halt (4-6 seconds)
4. Pick up trot and trot down center of arena.
5. Trot a figure eight with one change of diagonal.
6. Trot out of eight. Half way up center, pick up a canter on the right lead.
7. Canter a figure eight with one simple or flying change of lead.
8. Stop. Drop stirrups. Pick up trot and track right.
9. Stop. Pick up stirrups and back four steps. Return to line

## PATTERN # 1

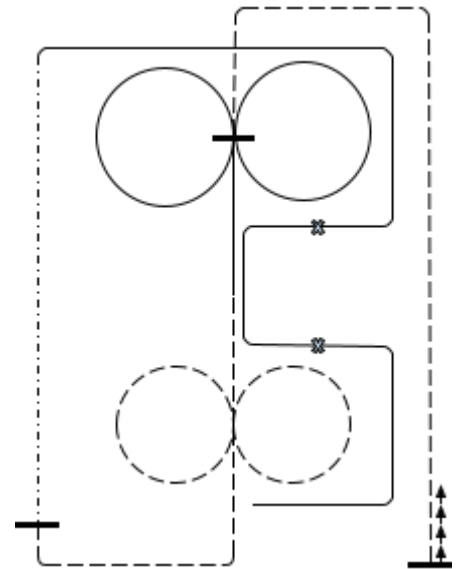

## HUNT SEAT FLAT

## SILVER MEDAL

Start pattern at center rail

1. Trot a serpentine with two diagonal changes.
2. Pick up canter and execute a serpentine with two simple lead changes.
3. Turn up center of arena and perform a figure eight with a simple or flying lead change.
4. Half way up the arena transition to a trot.
5. Trot a figure eight with one diagonal change.
6. Stop. Drop stirrups. Pick up a trot and track right.
7. Stop. Pick up stirrups and canter.
8. Increase speed to a hand gallop.
9. Pull up and halt (4-6 seconds). Back five steps. Return to line

## PATTERN # 2

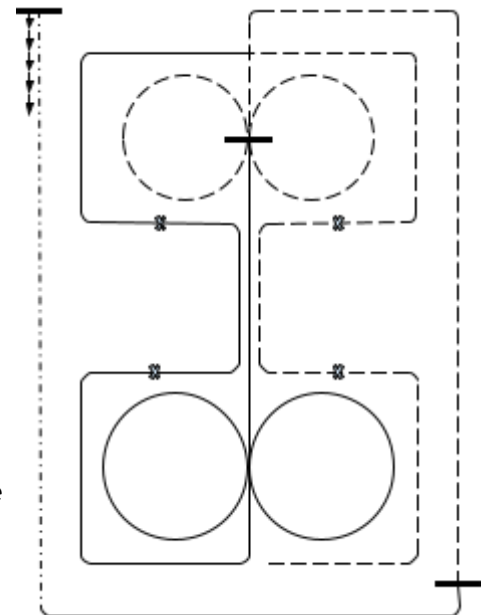

## HUNT SEAT FLAT

## SILVER MEDAL

## PATTERN #3

Start pattern at center rail

1. Trot a figure eight showing one change of diagonal. Halt.
2. Trot a serpentine with two diagonal changes.
3. Canter a serpentine with two simple lead changes,
4. Canter a figure eight with one simple or flying lead change.
5. Continue out of eight and turn right.
6. At corner increase speed to a hand gallop.
7. Pull up and halt (4-6 seconds). Back three steps.
8. Execute a 180-degree turn on the forehand to the left. Drop stirrups and pick up a trot.
9. Stop. Pick up stirrups. Return to line at the walk.

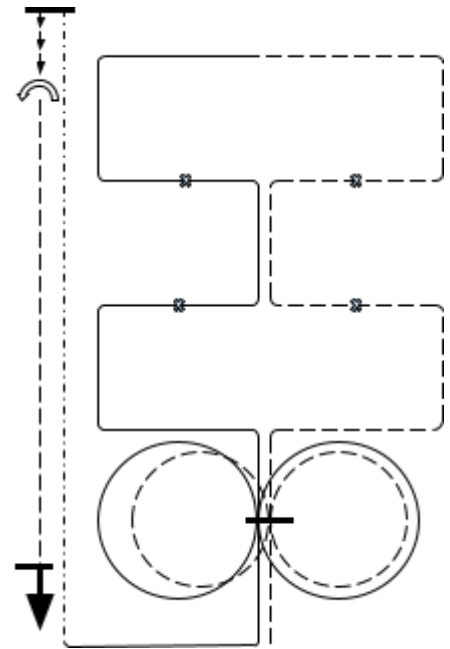

## HUNT SEAT FLAT

## SILVER MEDAL

## PATTERN #4

1. Back out of line then execute a 90-degree turn on the forehand.
2. Pick up canter and turn up center of arena
3. Canter a figure eight with one simple or flying lead change.
4. Stop. Drop stirrups and pick up trot on either diagonal.
5. Stop. Pick up stirrups and trot a figure eight with one diagonal change.
6. Trot about 20 feet out of figure eight and pick up canter on right lead. Continue around corner.
7. Increase speed to hand gallop down rail,
8. Pull up and halt (4-6 seconds)
9. Canter a four loop serpentine with three simple lead changes.
10. Transition to trot and trot a four loop serpentine with three diagonal changes
11. Stop. Return to line at a trot.

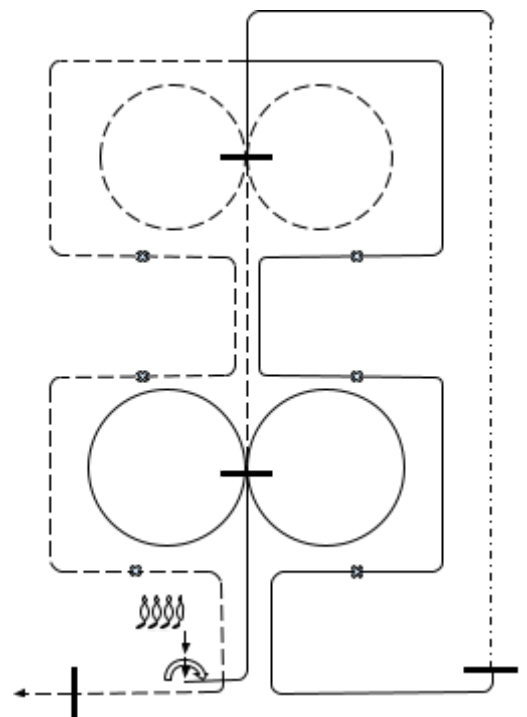

## HUNT SEAT FLAT GOLD MEDAL REQUIREMENTS

For Hunt Seat Flat, each contestant shall perform a demonstration pattern of not less than three minutes or more than four minutes. Pattern must include at least one item from each of the first five sets listed below. Tests may be performed in any order and may be repeated. Contestants must prepare and provide at least two copies of the pattern he/she plans to demonstrate in writing, to be turned in for approval to the show office at time of registration. The pattern should be the member's original design. It should not be the same pattern as any pattern included in the Rules/Medals publications or posted before or at the show. Medals coordinator or his/her designee shall verify that all elements are included. The judge may ask for additional tests.

### SET 1

- Halt (4-6 seconds).
- Back up to eight steps.
- Hand gallop and halt.

### SET 2

- Figure eight(s) at a trot, demonstrating change of diagonals.
- Serpentine at a trot, demonstrating change of diagonals.
- Trot down center of arena or down rail demonstrating change of diagonals.

### SET 3

- Figure eight(s) at a canter demonstrating simple changes of lead.
- Serpentine at a canter demonstrating simple changes of lead.
- Canter down center of arena demonstrating simple lead change.

### SET 4

- Figure eight(s) at a canter demonstrating flying changes of lead.
- Serpentine at a canter demonstrating flying changes of lead.
- Canter down center of arena demonstrating flying lead change.

### SET 5

- Execute half turns on the haunches.
- Execute half turns on the forehand.
- Canter on counter lead.

### OPTIONAL

- Ride without stirrups or drop and pick-up stirrups.

---

Notes:

## HUNT SEAT FLAT

## SUPREME AWARD

1. Trot a serpentine with two diagonal changes.
2. Trot a figure eight with one diagonal change.
3. Stop. Do a 180-degree turn.
4. Pick up canter and canter a serpentine with two flying lead changes.
5. Turn up center and canter a figure eight with one simple change of lead.
6. Stop. Drop irons and trot up center of arena.
7. Stop. Pick up irons and canter on right lead (track).
8. Increase speed to hand gallop.
9. Pull and halt (4-6 seconds) and back four steps return to line.

## PATTERN # 1

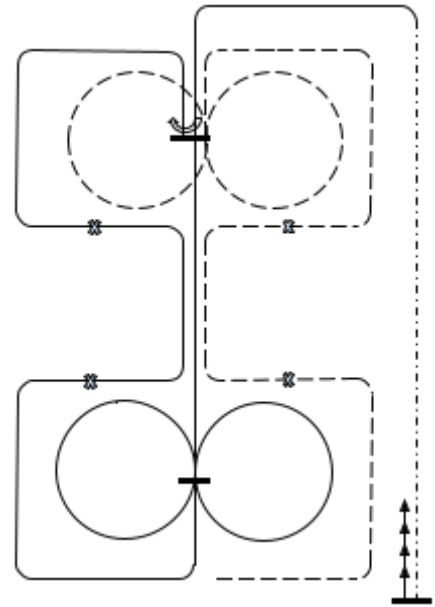

## HUNT SEAT FLAT

## SUPREME AWARD

Start at center rail.

1. Canter a serpentine with two flying lead changes.
2. Trot a serpentine with two diagonal changes.
3. Turn up center and trot a figure eight with one diagonal change.
4. Stop. Drop stirrups and trot down center.
5. Stop. Pick up stirrups and canter a figure eight with one simple change.
6. Continue out of figure eight and track right.
7. Increase speed to hand gallop.
8. Pull up and halt (4-6 seconds). Execute a forehand turn to the left.
9. Pick up right lead and at halfway point transition to sitting trot.
10. Pull up and halt (4-6 seconds). Then back three steps.

## PATTERN # 2

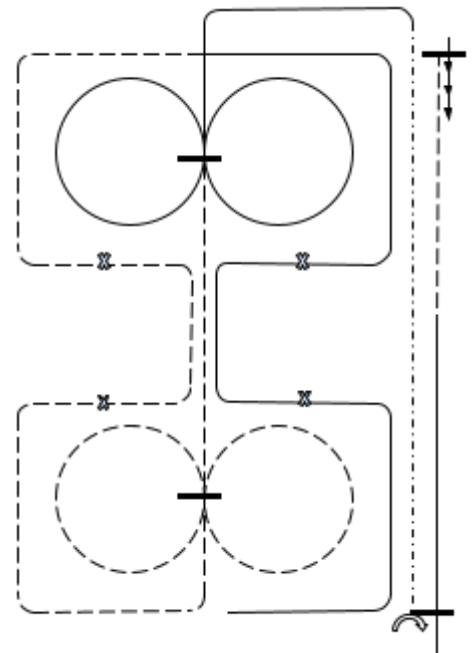



## HUNT SEAT FLAT

## SUPREME AWARD

## PATTERN # 3

Start pattern at center of arena.

1. Trot up center at the sitting trot.
2. Stop. Drop irons and trot a figure eight with one diagonal change.
3. Stop. Pick up irons. Execute a 180-degree forehand turn to the right and pick up canter on left lead and track left.
4. Execute two lead changes down the rail.
5. Turn down center of arena and canter a figure eight with one flying lead change.
6. Stop. Execute a 180-degree turn on the haunches to the left and pick up canter on left lead and track left.
7. Increase speed to hand gallop.
8. Pull up and halt
9. Back five steps.

Return to line at the walk.

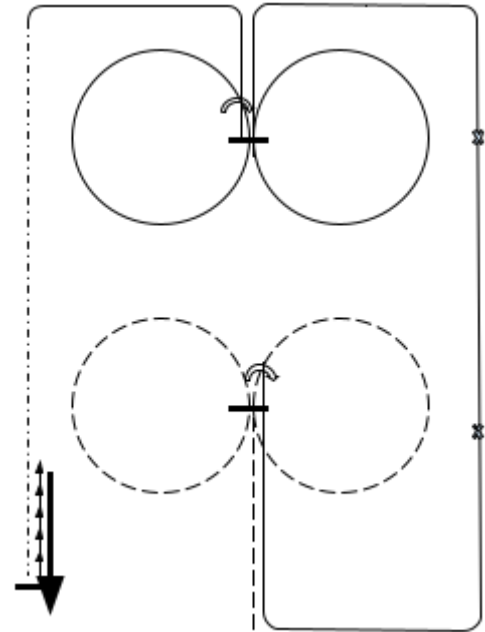

## HUNT SEAT FLAT

## SUPREME AWARD

## PATTERN #4

1. Enter working trot, at 1 extend the trot down the rail.
2. Pick up canter, canter serpentine with two flying lead changes.
3. Hand gallop down the rail. Working canter before corner.
4. Drop to trot and trot serpentine with two diagonal changes.
5. Extend the trot across the arena.
6. Pick up canter and canter around end of arena and into center.
7. Demonstrate one figure 8 with two flying lead changes.
8. Trot to end and halt.
9. Back one horse length.

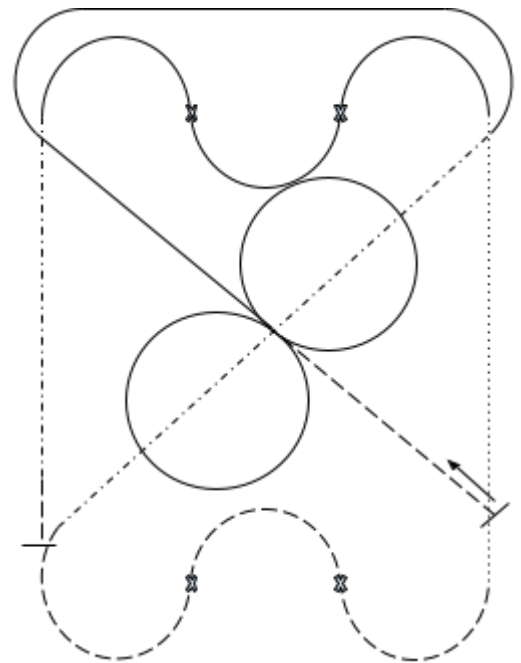

## SHOWMANSHIP MEDAL AND SUPREME AWARD COMPETITION

- A. Must comply with requirements stated in *Pacific Northwest 4-H Horse Contest Guide*, for Showmanship.

An Exhibitor must run two events at a 4-H Western Games Show if signed up for Showmanship medal classes with the same project horse.

- B. Judges must choose a pattern from the four patterns provided for each level. Patterns must be posted at least one hour prior to the class.
1. Bronze Medal: Patterns from pages 35 & 36
  2. Silver Medal: Patterns from pages 37 & 38
  3. Gold Medal: Each contestant shall perform a demonstration pattern of three minutes (see Appendix A for specific pattern requirements). Contestants must prepare and provide at least two copies of the pattern he/she plans to demonstrate in writing, to be turned in for approval to the show office at time of registration. The pattern should be the member's original design. It should not be the same pattern as any pattern included in the Rules/Medals publications or posted before or at the show. The judge may ask for additional tests.
  5. Supreme Award: Patterns from pages 40 & 41. The judge will determine if the exhibitor's execution of the pattern merits the awarding of one Supreme point. When an exhibitor has accumulated three Supreme points in Showmanship, he or she will be eligible to receive a Showmanship Supreme Award.

## SHOWMANSHIP

## BRONZE MEDAL

1. Start at A.
2. Trot from A to B.
3. At B, stop. Turn 360-degrees on the haunches. Stop.
4. Walk to C. Stop.
5. Back four steps, pause, step forward to original position. Stop.
6. Turn 90-degrees to the right.
7. Trot to D and set up for inspection.
8. After inspection, judge will ask a question about the parts of the horse.
9. Exhibitor is excused to lineup.

## PATTERN # 1

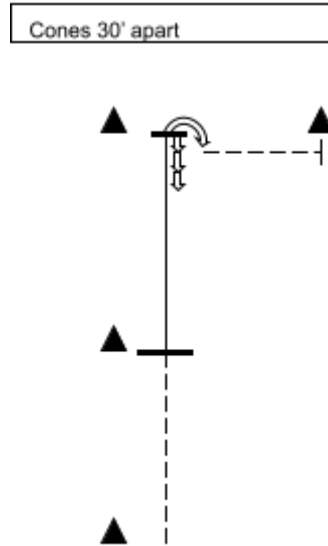

## SHOWMANSHIP

## BRONZE MEDAL

1. At A, perform a 360-degree turn.
2. Trot to B. At B, turn right and trot a circle, about 30' in diameter.
3. At B, stop. Back three steps.
4. Walk to C and set up for inspection.
5. Judge will ask a question about the parts of the horse.
6. Exhibitor is excused to line up.

## PATTERN # 2

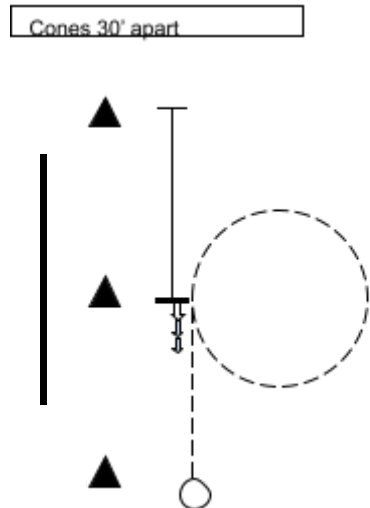

## SHOWMANSHIP

## BRONZE MEDAL

## Pattern # 3

1. Begin at B.
2. Turn 180-degrees on the haunches.
3. Walk to A. Stop.
4. Turn 180-degrees on the haunches.
5. Back three steps.
6. Trot to C. Stop.
7. Turn 270-degrees on the haunches.
8. Back to D. Set up for inspection.
9. After inspection, judge will ask a question about the parts of the horse.
10. Exhibitor is excused to the line-up.

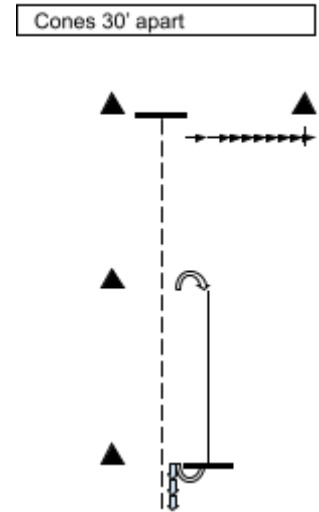

## SHOWMANSHIP

## BRONZE MEDAL

## Pattern # 4

1. Start at A.
2. Trot to B.
3. At B, turn left and trot a teardrop around C.
4. Trot to B and stop. Back six steps.
5. Turn 360-degrees on haunches.
6. Walk to B stop.
7. Set-up for inspection.
8. After inspection, judge will ask a question about the parts of the horse.
9. Exhibitor is excused to line up.

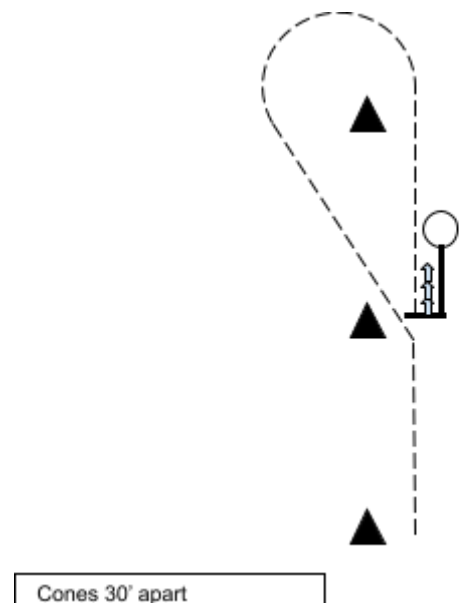

## SHOWMANSHIP

## SILVER MEDAL

## PATTERN # 1

1. Start at A. Walk to B.
2. At B, stop. Back three steps. Turn 360-degrees on the haunches.
3. Trot a figure eight. Circles should be about 30' in diameter, to the right first
4. Continue trotting to C. Side pass about five steps to the right.
5. Turn 90-degrees to the left on the forehand. Walk to D. Stop.
6. At D set up for inspection.
7. After inspection, pick up horse's forefoot designated by judge.
8. Judge may ask a question.
9. Exhibitor is excused to line up.

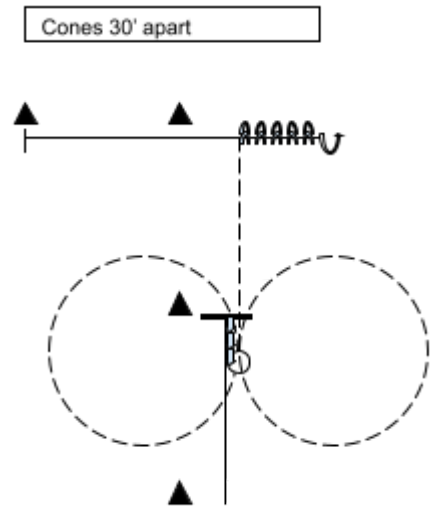

## SHOWMANSHIP

## SILVER MEDAL

## PATTERN # 2

1. Start at D.
2. Walk to C. Turn 90-degrees on the right forehand.
3. Back four steps.
4. Trot to B. At B, begin trotting a figure eight to the right first. Circles should be about 30' in diameter.
5. After completing figure eight, stop at B. Turn 360-degrees on the haunches.
6. Walk to A. Stop. Side pass about five steps to the right
7. Set up for inspection. After inspection, pick up forefoot judge directs.
8. Judge may ask a question.
9. Exhibitor is excused to line up.

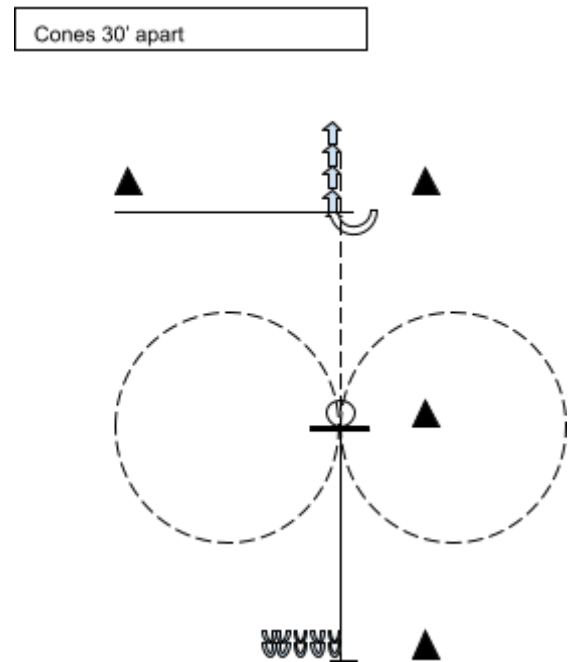

## SHOWMANSHIP

## SILVER MEDAL

## PATTERN # 3

1. Start at A.
2. Trot a figure eight, starting to the right, each circle being about 30' in diameter. Continue trotting to B and stop.
3. Turn 360-degree turn on the haunches. Walk to C.
4. Back three steps. Turn 90-degrees on the left forehand.
5. Walk to D. Stop. Side pass about five steps to the left. Set up for inspection.
6. After inspection, pick up horse's forefoot judge directs.
7. Judge may ask a question.
8. Exhibitor is excused to line up.

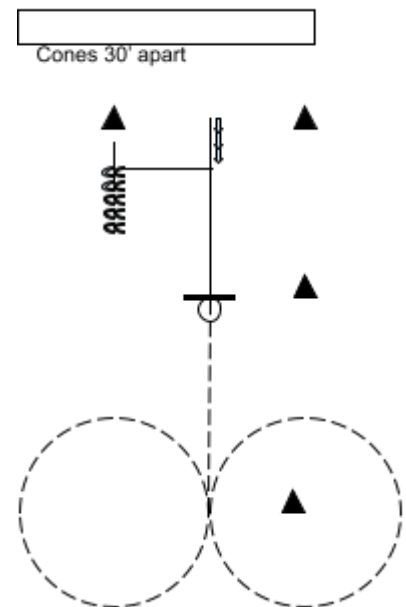

## SHOWMANSHIP

## SILVER MEDAL

## PATTERN # 4

1. Start at D.
2. Trot a figure eight, to the right first, with circles being about 30' in diameter. Continue trotting to C.
3. Stop at C. Back three steps. Turn 90-degrees on the right forehand.
4. Walk to B. Stop. Turn 360-degrees on the haunches.
5. Trot to A. Stop.
6. Side pass about five steps to the right.
7. Set up for inspection. After inspection, pick up forefoot judge directs.
8. Judge may ask a question.
9. Exhibitor is excused to line up.

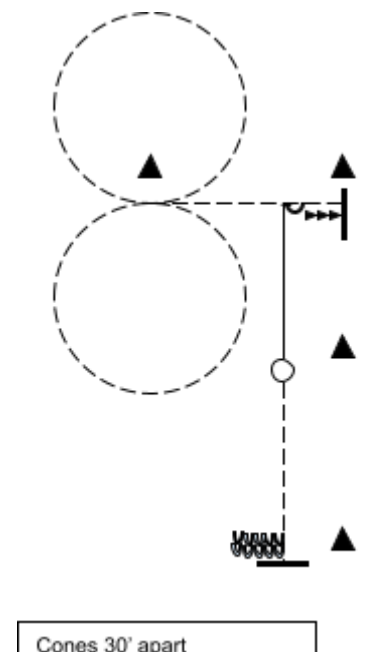

## SHOWMANSHIP GOLD MEDAL REQUIREMENTS

For Showmanship, patterns should be approximately three minutes. Pattern must include at least one item from each set listed below for the seat in which they are qualified. Tests may be performed in any order and may be repeated. Contestants must prepare and provide at least two copies of the pattern he/she plans to demonstrate in writing, to be turned in for approval to the show office at time of registration. The pattern should be the member's original design. It should not be the same pattern as any pattern included in the Rules/Medals publications or posted before or at the show. The judge may ask for additional tests.

### SET 1

- Lead horse at a trot in a straight line.
- Lead horse at a trot in a circle.

### SET 2

- Back horse in a straight line.
- Back horse in "L" shape.

### SET 3

- 360-degree on haunches to the right.
- 180-degree turn on forehand.

### SET 4

- Lead from off (right) side.
- Side pass.

### SET 5

- Answer questions on grooming and showing of specific breeds.
- Demonstrate (or describe) proper use of whip & chain.

### OPTIONAL

- Answer questions on parts of the horse. (Judge will determine questions).

---

NOTES:

## SHOWMANSHIP

## SUPREME AWARD

## PATTERN # 1

1. Start at A.
2. Trot a serpentine around cones. Stop at C.
3. Side pass about five steps to the left.
4. Turn 270-degrees on right haunch.
5. Walk to D. Stop. Back three steps
6. Turn 270-degrees on right haunch.
7. Trot to and around E. Stop where indicated. Turn 180-degrees on right forehand.
8. Stay on the off side.
9. Walk half way to F. Half way, begin trotting. Stop and set up from off side at F.
10. After inspection, pick up any of four feet directed by the judge.
11. Exhibitor is excused to line-up.

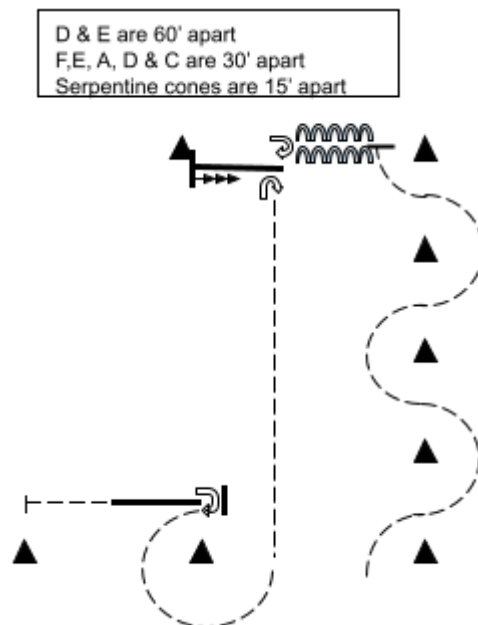

## SHOWMANSHIP

## SUPREME AWARD

## PATTERN # 2

1. Start at F.
2. Trot a circle around E, about 30" in diameter.
3. Stop where indicated. Move to off side.
4. Walk horse half way to D on off side. Trot the rest of the way to D on off side. Stop at D.
5. Return to near side. Turn 90-degrees on the right haunches. Walk to C.
6. Turn 90-degrees on the right forehand. Back three steps.
7. Side pass about three steps to the left. Trot serpentine through cones. Stop at A.
8. Move to off side and set up for inspection. After inspection, pick up any foot judge directs.
9. Exhibitor excused to line up.

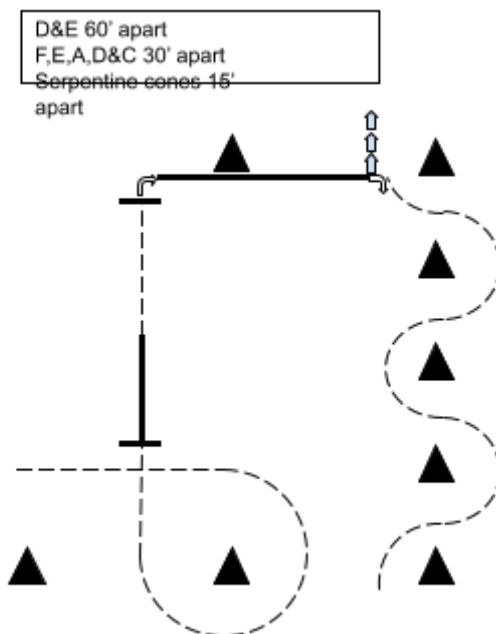



## SHOWMANSHIP

## SUPREME AWARD

## PATTERN #3

1. Begin at A.
2. Trot serpentine, continue trotting all the way around C. Stop where indicated.
3. Move to off side. Turn 180-degrees on the left haunch. Stop. Return to near side. Turn 180-degrees on right haunch. Stop.
4. Walk to D. Turn 90-degrees on left forehand Stop.
5. Side pass left. Stay on off side. Walk halfway to E then trot to E. Stop.
6. Return to near side. Back three steps.
7. Side pass right.
8. Turn 90-degrees on haunch. Walk to F. Turn 180-degrees on right forehand. Set up from off side.
9. After inspection, pick up foot judge directs.
10. Exhibitor is excused to line up.

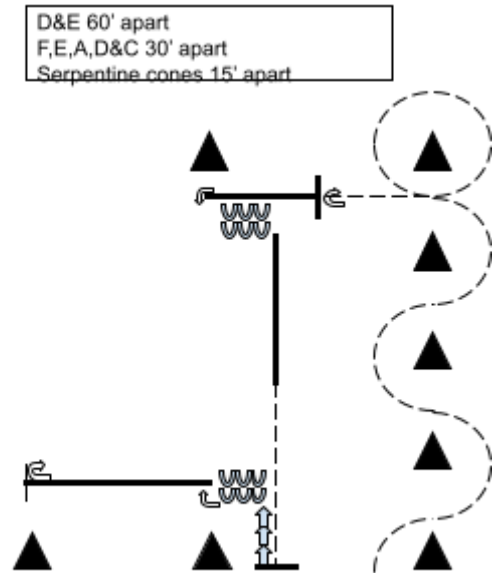

## SHOWMANSHIP

## SUPREME AWARD

## PATTERN #4

1. Begin at cone F
2. Trot to cone E, trot a circle around E, halt.
3. Back 6 steps, halt, perform a 270 haunch turn, halt.
4. Move to off side, trot halfway to cone D, at halfway point transition to walk, walk to D and halt.
5. Back a half circle around D, perform a 270 forehand turn, walk to C, halt.
6. Sidepass four crossovers to the left, return to the on side.
7. Trot off, serpentine cones. Halt at A and set up for inspection.

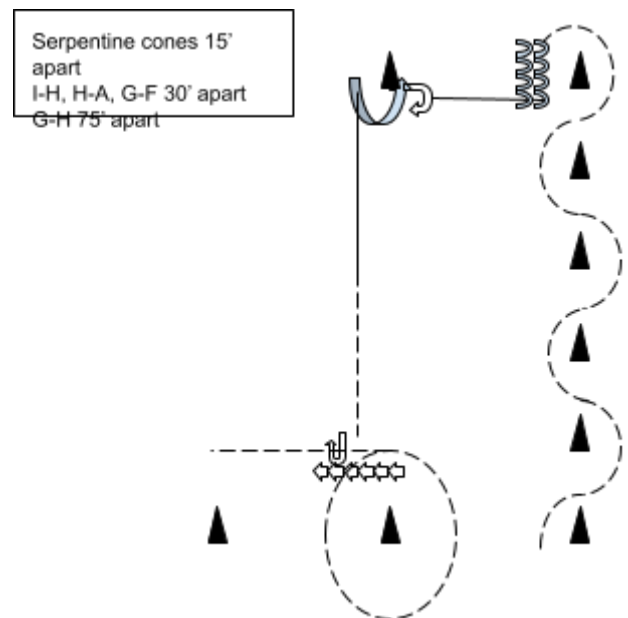

## TRAIL MEDAL AND SUPREME AWARD COMPETITION

- A. Must comply with requirements stated in *Pacific Northwest 4-H Horse Contest Guide*, for Stock Seat, Hunt Seat, or Saddle Seat equitation.
- B. Eligibility  
To become eligible for trail medal competition, a rider must receive 3 danish blue ribbons or a high blue at a King County 4-H Medals show or the King County Fair/qualifying event. The course must have 10 obstacles.
- C. Tests from which the judge must choose:
- |                                                   |                                               |
|---------------------------------------------------|-----------------------------------------------|
| 1. Gate*                                          | 12. Walk up to or pass plastic, paper, canvas |
| 2. Bridge                                         | 13. Logs                                      |
| 3. Walk-over or lead-over                         | 14. Put on or remove coat or slicker          |
| 4. Back through obstacle*                         | 15. Carry an object                           |
| 5. Bank                                           | 16. Jog-over                                  |
| 6. Water crossing                                 | 17. Lope-over                                 |
| 7. Mailbox                                        | 18. Serpentine (jog-around)                   |
| 8. Mount and dismount                             | 19. Turns from either side                    |
| 9. Side-pass                                      | 20. Tie manger knot                           |
| 10. Walk through brush                            | 21. Tie bowline knot                          |
| 11. Questions from current 4-H project materials. |                                               |

*Backing through a gate is not allowed as a test when the gate is metal.*

- D. Requirements for specific classes
1. Show management or Judges may design the pattern. Patterns are to be given to the show office for approval by the medals chairman or his/her designee and must be posted at least one hour prior to the class.
  2. 10 obstacles must be used. Rail work is not required.
  3. Score per obstacle shall be 0-10 with the 10 being the highest. A rider needs a minimum score of 5 points per obstacle to earn a medal or Supreme point. Example: A good overall score on all obstacles, yet a score of 4 on the bridge will disqualify the rider for a medal.
  4. Medals to be determined by judge just like all other medals. Riders do not make their own gold medal pattern. This pattern is to be provided by management or judge.
  5. Gold medals: When a rider is attempting a gold medal ride they must also pass a written test. Once passed the rider does not have to re-take the test.
  6. Supreme: When an exhibitor has accumulated three supreme points in Trail, he or she will be eligible to receive a Trail Supreme Award.

## REINSMANSHIP MEDALS PROGRAM

### A. Eligibility:

To participate in the reinsmanship medals program rider must have received a high blue in reinsmanship, and have a horse certificate on file by April 1st with the horse it is earned with. All subsequent medals may only be earned if the rider has a horse certificate on file by April 1<sup>st</sup> of that 4-H year.

### B. Qualifying class:

Reinsmanship

### C. Class routine:

Individual performance of a pattern chosen by the judge. Patterns are available in this book.

### D. To be judged on:

50% Handling of reins, whip, control, posture, and overall appearance.

25% Movement, transitions, pattern.

25% Proper harnessing, hitching, and condition of harness, horse, and neatness.

### E. The Judge will use the following terminology:

**Walk:** A free, regular and unconstrained walk of moderate extension is required; the horses should walk energetically, but calmly, with even and determined pace.

**Lengthened walk:** A more ground covering walk while showing the lengthening of frame and stride.

**Collected trot (Slow trot):** The horse should maintain forward impulsion while showing submission to the bit. The trot is slower and more collected, but not to the degree required in the dressage collected trot. However, the horse should indicate willingness to be driven on the bit while maintaining a steady cadence.

**Working Trot:** This is the pace between the strong and slow trot, more round than a strong trot. The horses go forward freely and straight; engaging the hind legs with good hock action; on a taut but light rein; the position being balanced and unconstrained. The steps should be as even as possible. The hind feet touch the ground in the foot prints of the forefeet. The degree of energy and the impulsion displayed at the working trot demonstrates clearly the degree of suppleness and balance of the horses.

**Extended Trot (Strong Trot):** Cover as much ground as possible. Lengthened stride while remaining on the bit with light control. The neck is extended, and the animal uses the shoulders covering more ground without the action becoming higher.

**Halt:** Horses and vehicles should be brought to a complete square stop without abruptness or veering. At the halt, horses should stand attentive and motionless and straight with weight evenly distributed over all four legs, ready to move off at the slightest indication of the driver.

**Rein back:** Rein back is defined as a backward movement in which the legs are raised and set down in diagonal pairs with the hind legs remaining well in line. To be performed in two parts:

1. The horse must move backward at least four steps in an unhurried manner with the head flexed and pushing the carriage backwards evenly in a straight line. The driver should use quiet aids and light contact.
2. Move forward willingly to former position using the same quiet aids.

## REINSMANSHIP MEDAL AND SUPREME AWARD COMPETITION

A. Must comply with the requirements stated in the Harness Driving Manual and Rules for Washington State (EM4881).

B. Judge may use an original pattern or choose a pattern from the three patterns provided for each level. Original patterns must use the tests designated for that class and be approved by the medals chairman.

Patterns are to be given to the medals chairman or his/her designee and must be posted one hour prior to the class.

1. Bronze Medal: Patterns from pages 46 & 47.
2. Silver Medal: Patterns from pages 48 & 49.
3. Gold Medal: Each contestant shall perform a demonstration pattern of not less than three minutes or more than four minutes. Pattern must include at least one item from each of the first five sets listed below. Tests may be performed in any order and may be repeated. Contestants must prepare and provide at least two copies of the pattern he/she plans to demonstrate in writing, to be turned in for approval to the show office at time of registration. The pattern should be the member's original design. It should not be the same pattern as any pattern included in the Rules/Medals publications or posted before or at the show. The judge may ask for additional tests.
4. Supreme Award: Patterns from pages 52 & 54. The judge will determine if the exhibitor's execution of the pattern merits the awarding of one Supreme point. When an exhibitor has accumulated three Supreme points in Reinsmanship, he or she will be eligible to receive a Reinsmanship Supreme Award.

**REINSMANSHIP**

**BRONZE MEDAL**

**PATTERN # 1**

1. AK Collected trot
2. KEH Extended Trot
3. HC Working trot, halt
4. C Pivot 180-degrees right, then left
5. CMB Working trot through three gates (cones)
6. BF Lengthened walk, halt
7. F Back four steps
8. FA Walk on a loose rein /exit.

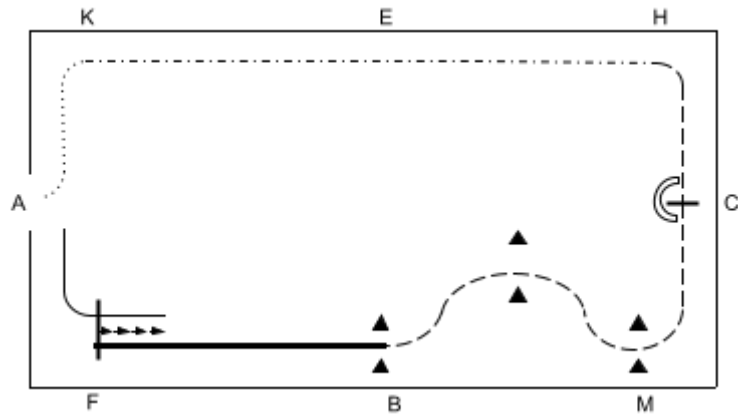

**REINSMANSHIP**

**BRONZE MEDAL**

**PATTERN # 2**

1. AG Working trot
2. G Execute figure eight, right circle first, working trot
3. CH Working trot
4. HXF Extended Trot
5. FAK Working Trot
6. KX Lengthened walk
7. X Back four steps
8. XBFA Walk on a loose rein/ exit

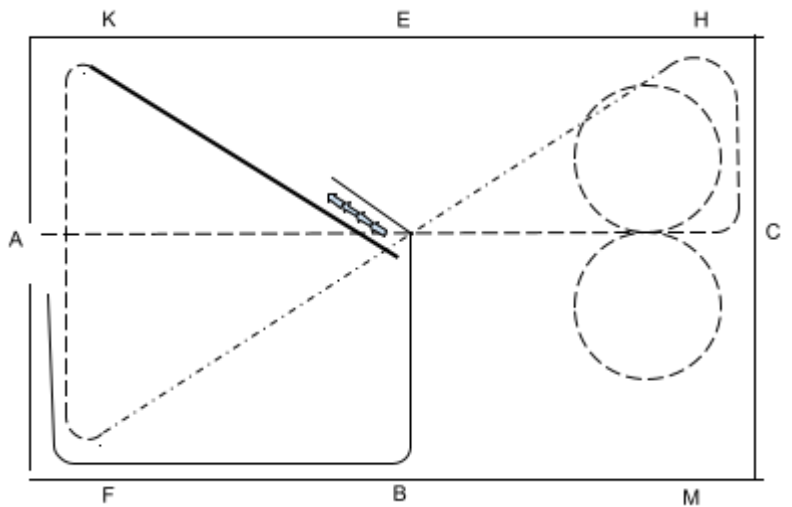

REINSMANSHIP

BRONZE MEDAL

PATTERN # 3

1. AX Working trot, halt at X
2. X Working trot figure eight (either direction)
3. X Halt, pivot 90-degrees to the right
4. X Walk
5. BM Pivot 90-degrees left; walk
6. MH A three loop serpentine at a working trot
7. HEK Extended Trot
8. K Halt, back four steps, lengthened walk to exit.

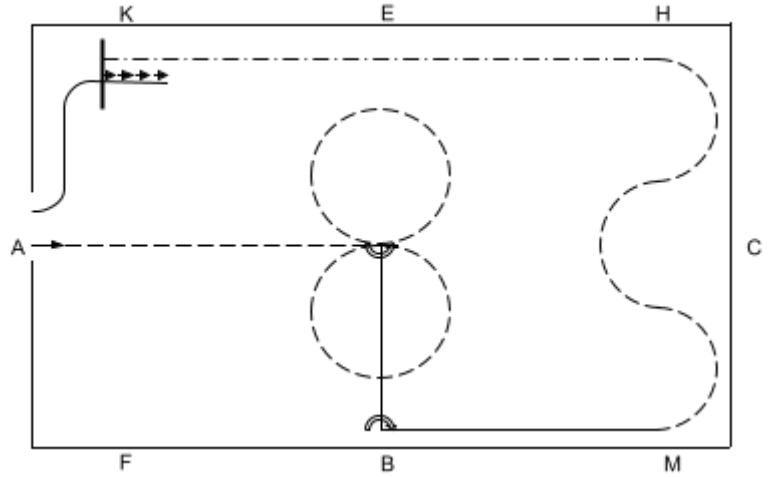

**REINSMANSHIP**

**SILVER MEDAL**

**PATTERN # 1**

1. AA Collected trot through a serpentine of four cones (past X and 25' apart) up and back to A
2. A Halt (facing gate)
3. A Pivot 90-degrees left, walk four steps, pivot 180-degrees left
4. AKEH Working trot
5. H Halt 10 sec. Back four steps
6. HM Working trot
7. MBF Extended trot
8. F Halt
9. FA Walk on loose rein/ exit

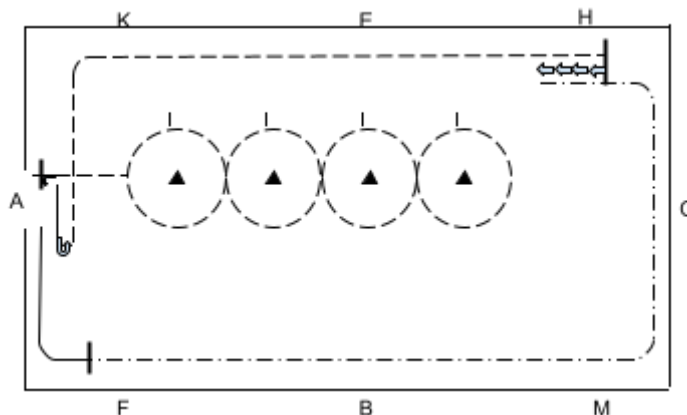

**REINSMANSHIP**

**SILVER MEDAL**

**PATTERN # 2**

1. AD Working trot
2. DX Left wheel through two ground poles – working trot
3. X Collected trot
4. C Halt, pivot 450-degrees
5. CM Walk
6. MBF Working trot a five cone serpentine (25' apart)
7. FAK Collected trot
8. KEH Extended trot
9. H Halt 10 sec, pivot 180-degrees right
10. HEKA Walk on a loose rein. Exit

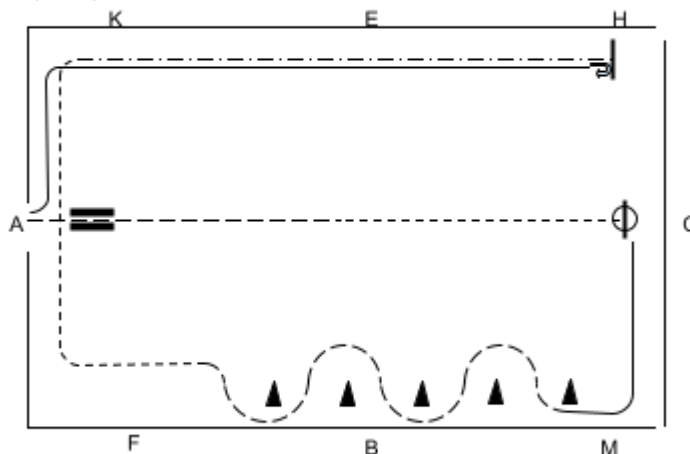

REINSMANSHIP

SILVER MEDAL

PATTERN # 3

1. AF Enter at A Working trot to
2. FBMC Extended Trot
3. CXA Begin serpentine at C execute 4 serpentine loops at the working trot.
4. AXC At A execute 4 serpentine loops at the collected trot
5. CH Working Trot, Halt Pivot 90-degrees to the left
6. HE Lengthened walk
7. E Halt, pivot 90-degrees left
8. EX Lengthened walk, halt, 90-degree pivot right
9. XA Walk on a loose rein to exit

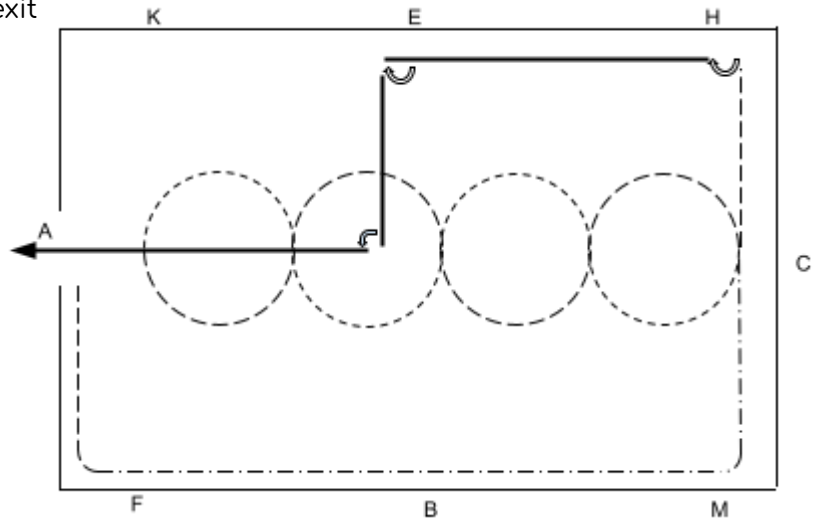



## REINSMANSHIP GOLD MEDAL REQUIREMENTS

For Reinsmanship, each contestant shall perform a demonstration pattern of not less than three minutes or more than four minutes. Pattern must include at least one item from each of the six sets listed below. Tests may be performed in any order and may be repeated. Contestants must prepare and provide at least two copies of the pattern he/she plans to demonstrate in writing, to be turned in for approval to the show office at time of registration. The pattern should be the member's original design. It should not be the same pattern as any pattern included in the Rules/Medals publications or posted before or at the show. Medals coordinator or his/her designee shall verify that all elements are included. The judge may ask for additional tests.

### SET 1

- Walk.
- Lengthened walk.

### SET 2

- Back.
- Halt.

### SET 3

- Working trot.
- Extended trot.

### SET 4

- Figure eight.
- Cones.

### SET 5

- 90-degree pivot.
- 180-degree pivot.

### SET 6

- Wheel through poles.
- Collected trot.

---

NOTES:

**REINSMANSHIP**

**SUPREME MEDAL**

**PATTERN # 1**

1. AX Collected trot, halt
2. X Pivot 360-degrees
3. XG Collected Trot
4. G Figure eight (either direction) using the one handed driving method
5. G Halt, Proceed using two handed driving method at a working trot
6. GCM Working Trot
7. MK Extended Trot
8. KAF Walk
9. F Halt, pivot 180-degrees left, back four steps
10. FA Walk on a loose rein. Exit

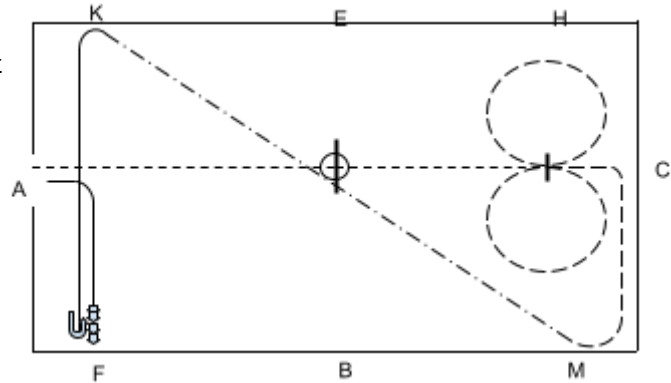

**REINSMANSHIP**

**SUPREME MEDAL**

**PATTERN # 2**

1. A Collected Trot
2. FM to Comer Extended Trot
3. Corner to E Lengthened walk with right wheel between two ground poles
4. E Halt, pivot 90-degrees left
5. EXB Working trot four cone serpentine
6. B Halt, pivot 450-degrees
7. BF Lengthened walk
8. F Halt, back four steps, pull forward four steps, halt and salute
9. FA Walk to exit on a loose rein

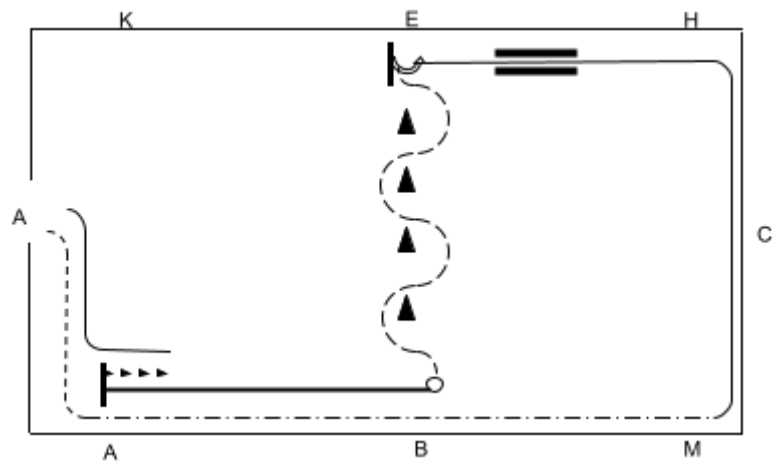

# REINSMANSHIP

# SUPREME MEDAL

# PATTERN # 3

1. AFM Extended trot
2. MCG Working trot, figure eight to the right, then left and left 3/4 of the way to C
3. CHE Collected trot
4. E Halt, 90-degree pivot left
5. EX Lengthened Walk
6. X Perform a backing "L" shape pivoting on the left wheel
7. XD Working Trot perform figure eight to the right then left
8. D Halt (10 seconds), salute
9. DA Walk on a loose rein to exit

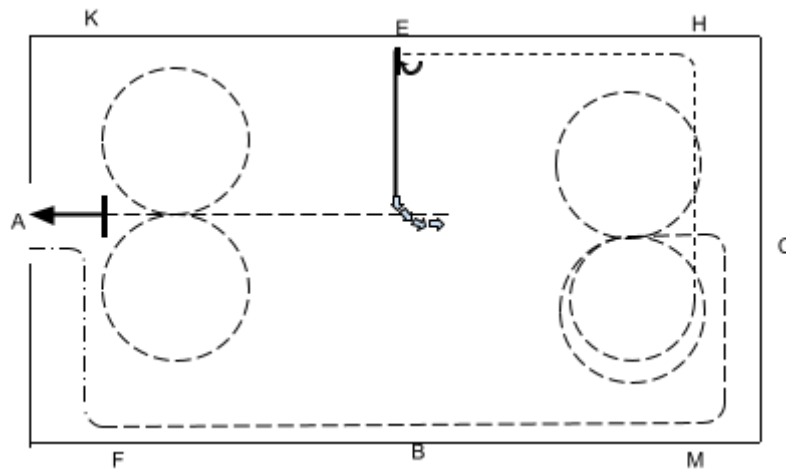

## HUNT SEAT OVER FENCES MEDAL AND SUPREME AWARD COMPETITION

- A. Must comply with requirement stated in *Pacific Northwest 4-H Horse Contest Guide*, for Hunt Seat equitation.
- B. Each medal class will consist of the exhibitor riding the course of fences to the best of his or her ability. There will be no flat or individual work.
  1. Determining the course from how the jumps are numbered is part of this class.
  2. Each exhibitor may circle once before approaching 1st fence. An exhibitor who is identified as going off course by the show judge should not receive a medal or be awarded points.
  3. Riders in bronze or silver medal classes will not be penalized for simple lead changes versus flying if lead changes are necessary. In gold and supreme classes, lead changes, if necessary, must be flying.
  4. Gold medal riders must design his/her course using jumps as set on gold medal diagram.
    - a. Gold medal riders should provide two copies of their course design to be turned in for approval to the show office at time of registration. The pattern should be the member's original design. It should not be the same pattern as any pattern included in the Rules/Medals publications or posted before or at the show.
    - b. Under no circumstances may exhibitor change position or height of jumps. Gold medal jump patterns do not need to include each fence at least once, nor the combination fence at all.
    - c. A minimum of eight and maximum of 10 jumps are to be used.
    - d. Course must have at least three changes of direction. When designing a course, exhibitor must clearly indicate with arrows the direction the course is being ridden.
    - e. The course is not timed because the number of jumps is limited.
  5. Supreme Award: The judge will determine if the exhibitor's execution of the course merits the awarding of one Supreme point. When an exhibitor has accumulated three Supreme points in Hunt Seat Equitation Over Fences, he or she will be eligible to receive a Hunt Seat Equitation Over Fences Supreme Award.

### HUNT SEAT OVER FENCES PROGRAM

The following equipment is required to set the courses included in this book:

- 20 standards with jump cups
- 26 poles
- At least two 150 foot tape measures
- Copies of course design for jump crew
- 68 strong bodies for crew

When setting the course, the jumps that are along the long sides of the ring (called lines) should be as centered as possible, making sure that there is the same amount of distance from the jump to the end of the ring at both ends of the arena.

All jumps must have a ground line on the take-off side (pay attention to this detail when Gold medal patterns are submitted). Ideally all jumps should have ground lines on both sides of each jump.

Gold medal jump patterns do NOT need to include each fence at least once nor the combination fence at all.

After each class, fence heights will need to be adjusted.

Distance between fences should be measured from jump cup to jump cup.

If brush boxes are available, they must be added to fences in the gold and supreme classes. Avoid making the first fence in the course a brush box. When a vertical jump is raised to 2'9", it should have at least two poles.

Each course has an oxer jump. It is distinguished on the course design by double lines for the poles. This is basically a double jump (see fence illustrations). Square oxers are prohibited. The rails must have a difference of at least 3" and not more than 6".

Jumps should be natural looking like those found in a hunt field.

Show management is required to provide a warmup jump in a practice area that is supervised by an appointed adult. Only exhibitors that are registered in the over fences classes should be allowed to jump this fence.

If size or condition of the arena will not accommodate the specified patterns, show management may alter courses with the judge's approval. The judge must be given a copy and must approve all gold medal course designs.

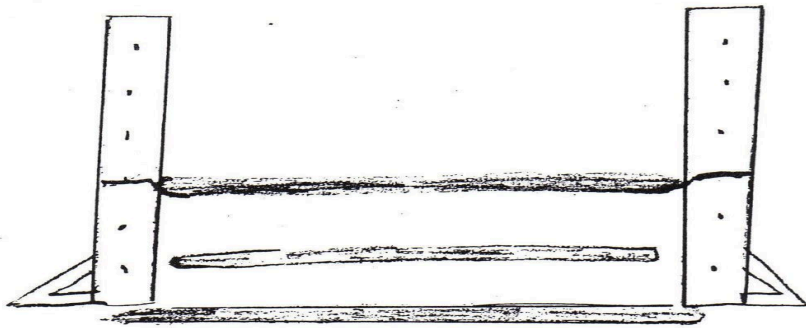

VERTICAL

Two Standards - Three Poles

Vertical jumps 2'9" and above should have second pole added below top pole.

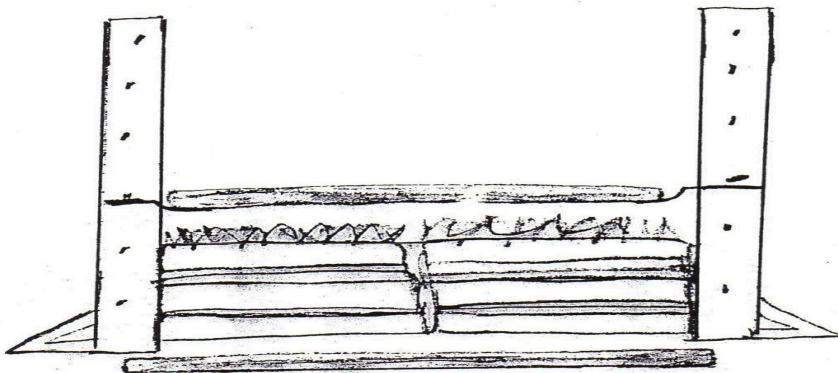

VERTICAL WITH BRUSH BOX

Two Standards - Three Poles - Brush Box

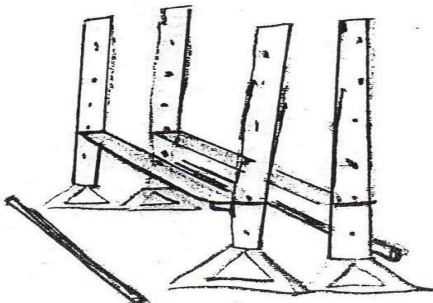

OXER

Four Standards - Four Poles

HUNT SEAT MEDALS BRONZE COURSE #1

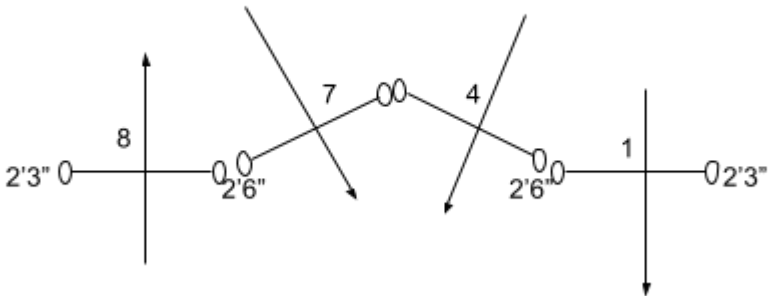
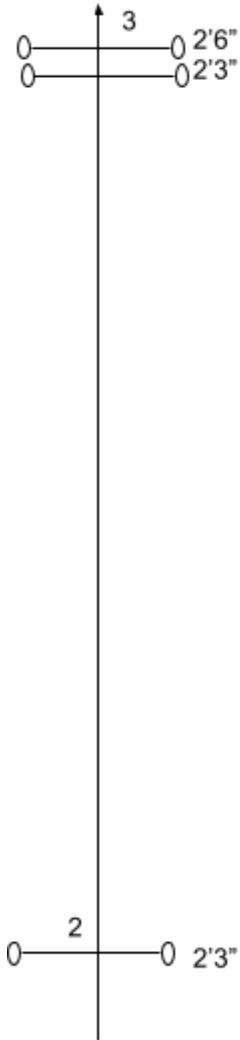

# HUNT SEAT MEDALS BRONZE COURSE #2

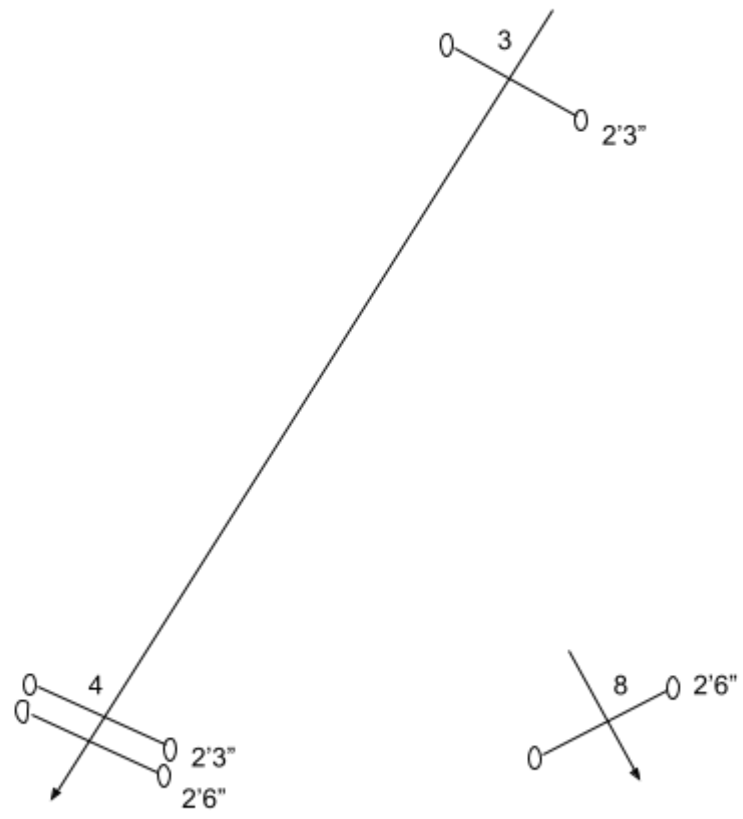
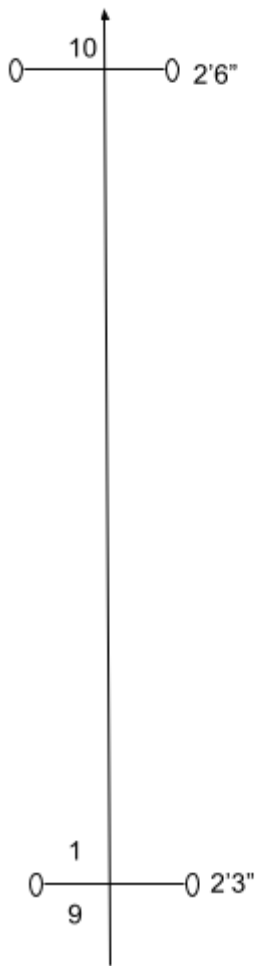

HUNT SEAT MEDALS BRONZE COURSE #3

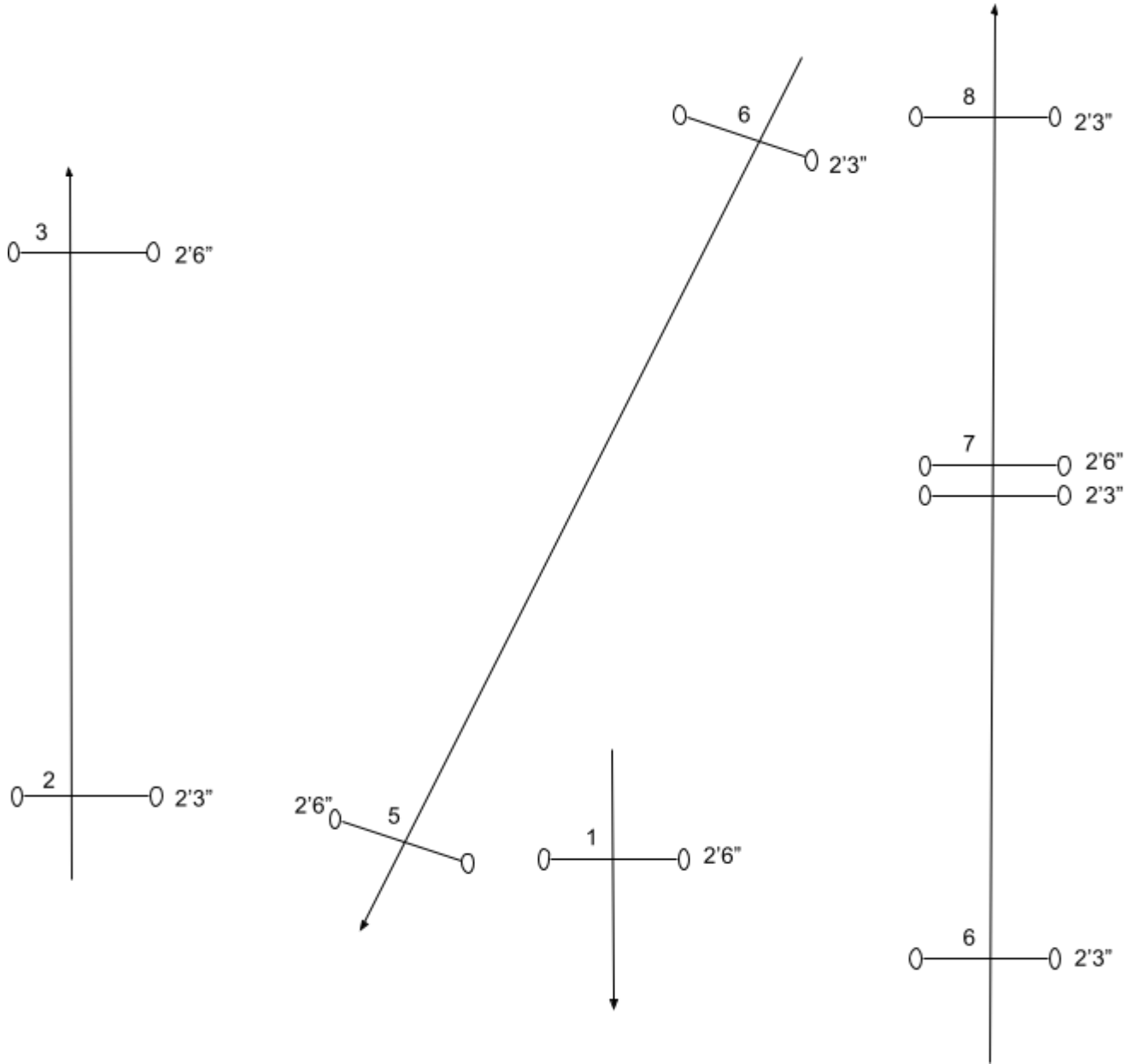



# HUNT SEAT MEDALS BRONZE COURSE #4

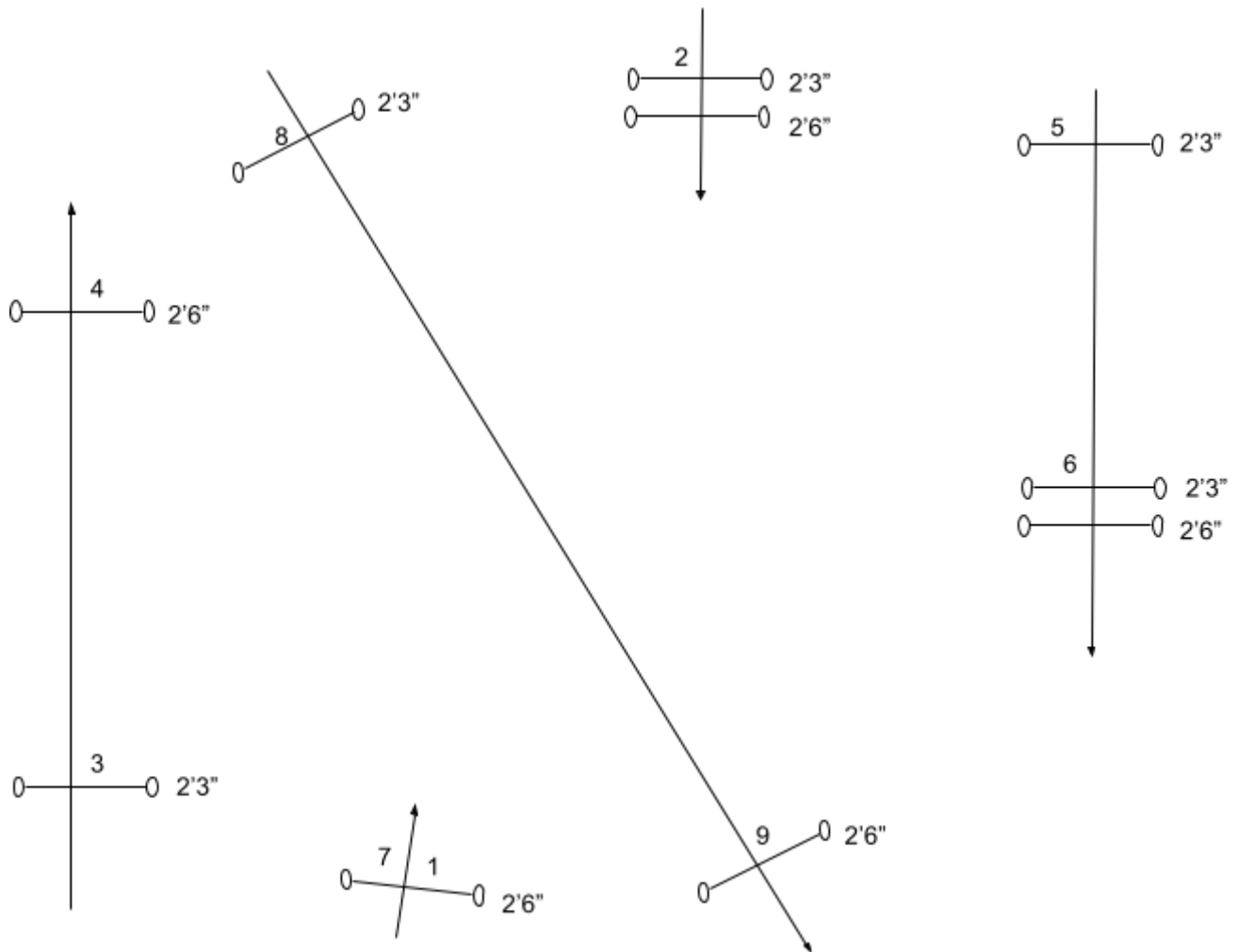

# HUNT SEAT MEDALS SILVER COURSE #1

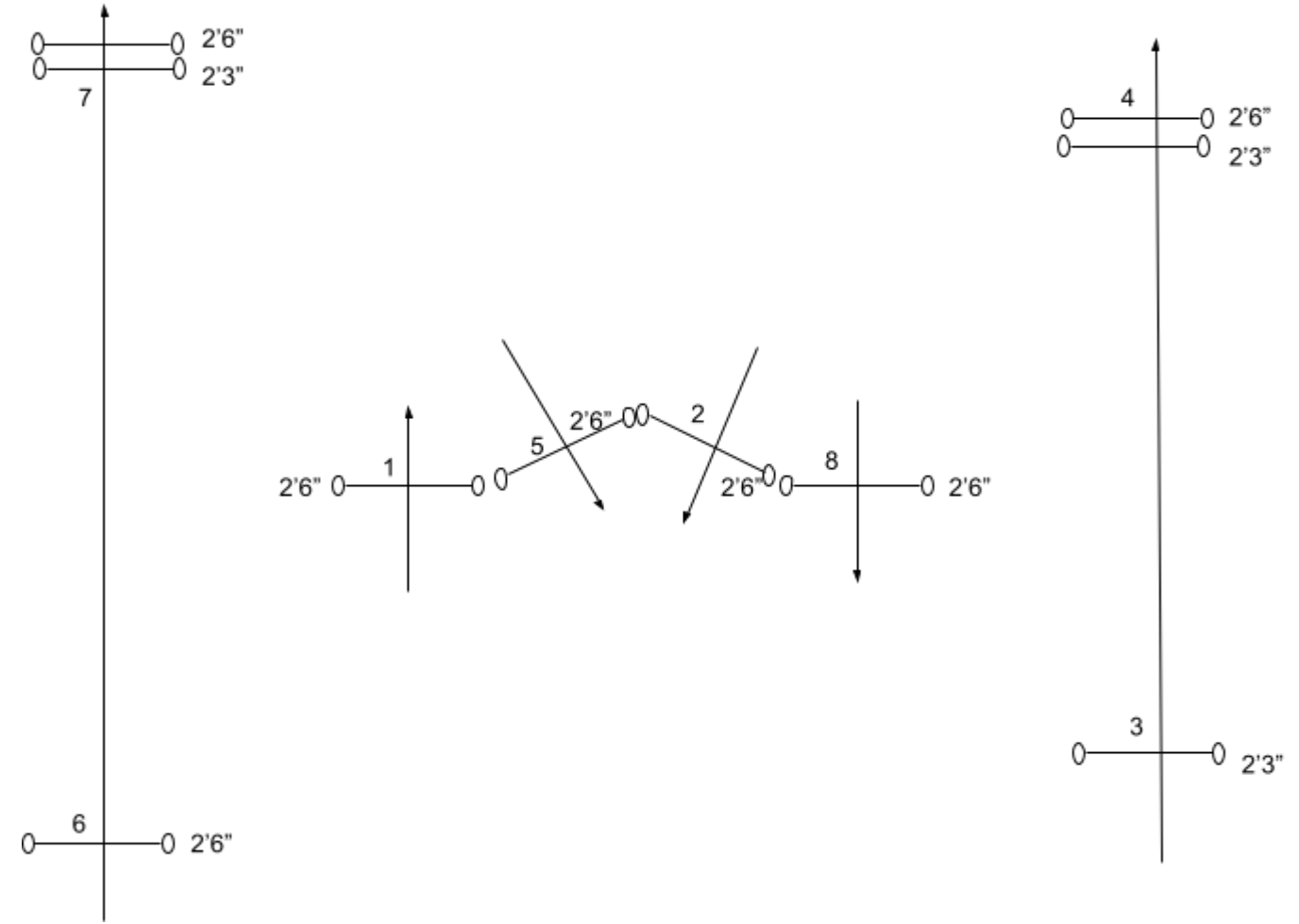

1

# HUNT SEAT MEDALS SILVER COURSE #2

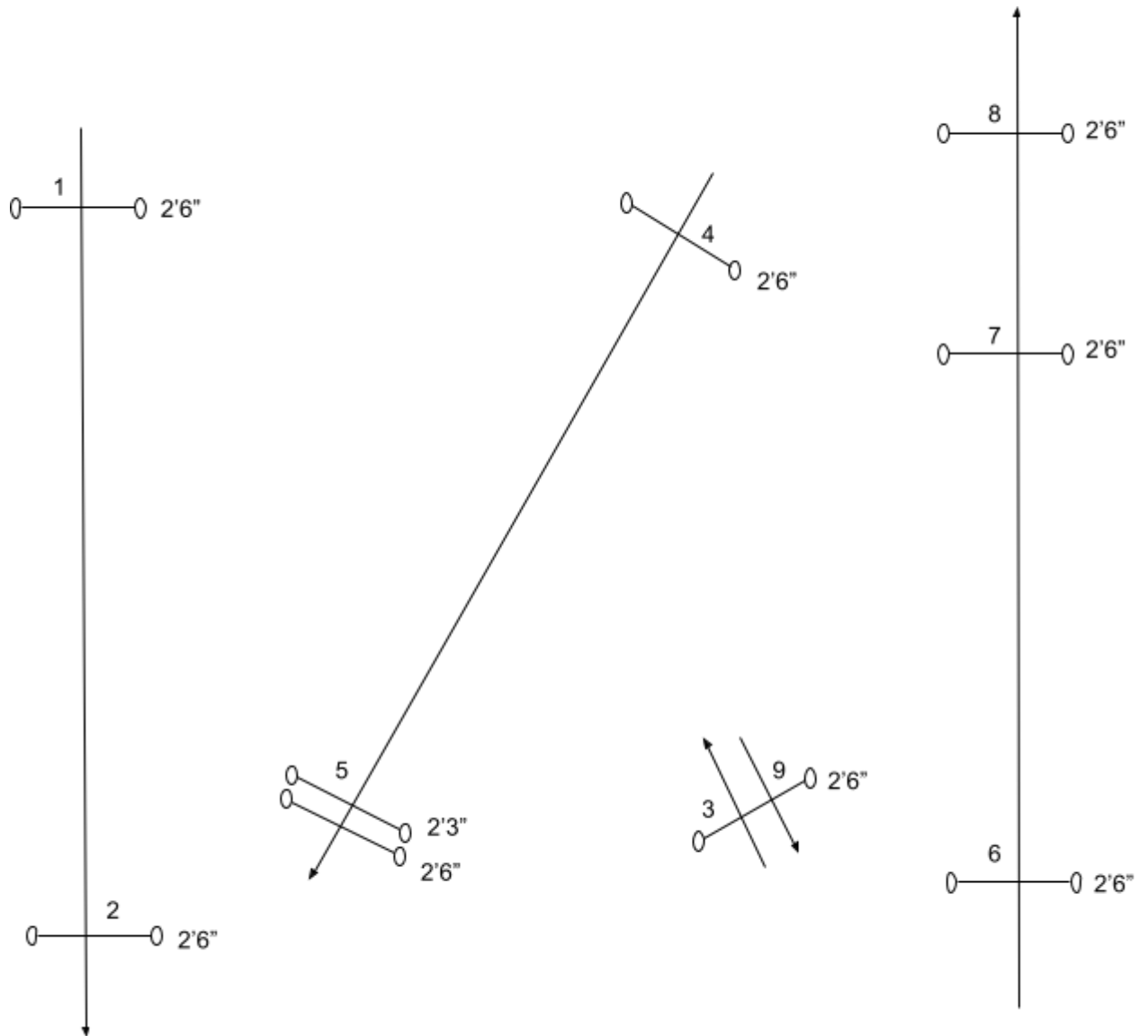

HUNT SEAT MEDALS SILVER COURSE #3

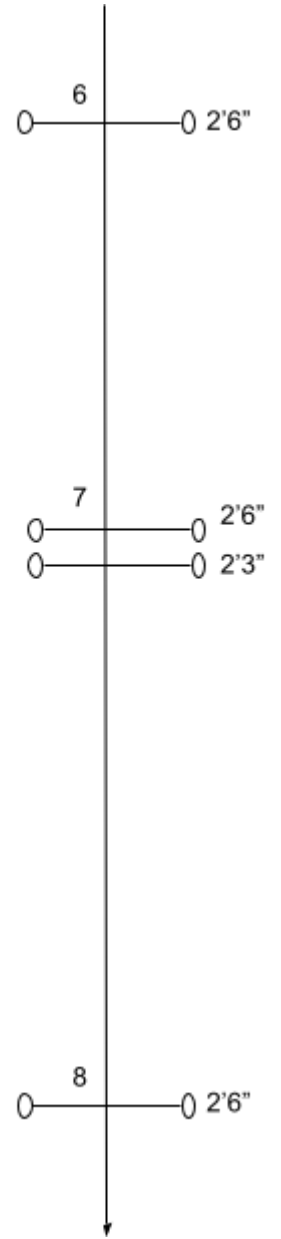
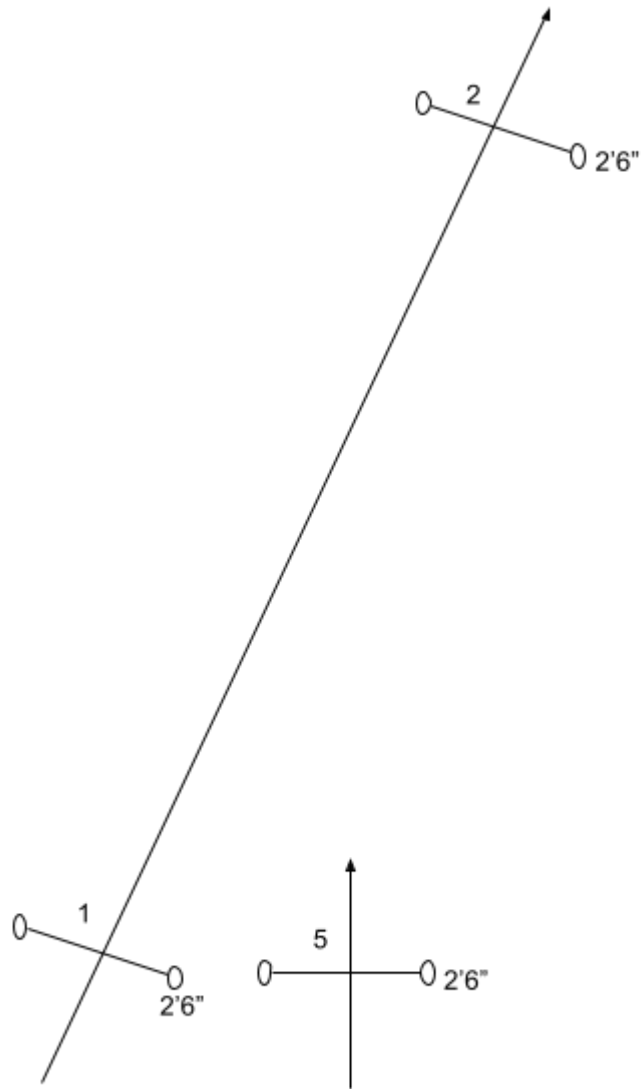
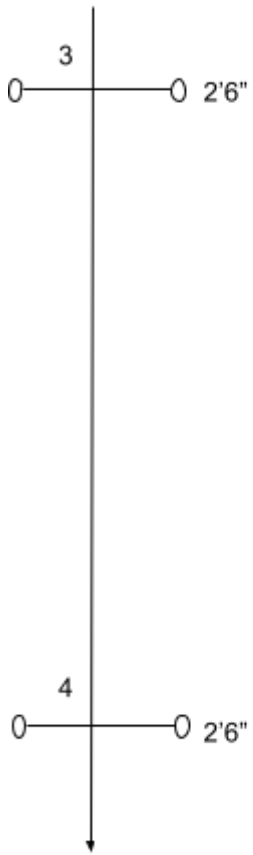

# HUNT SEAT MEDALS SILVER COURSE #4

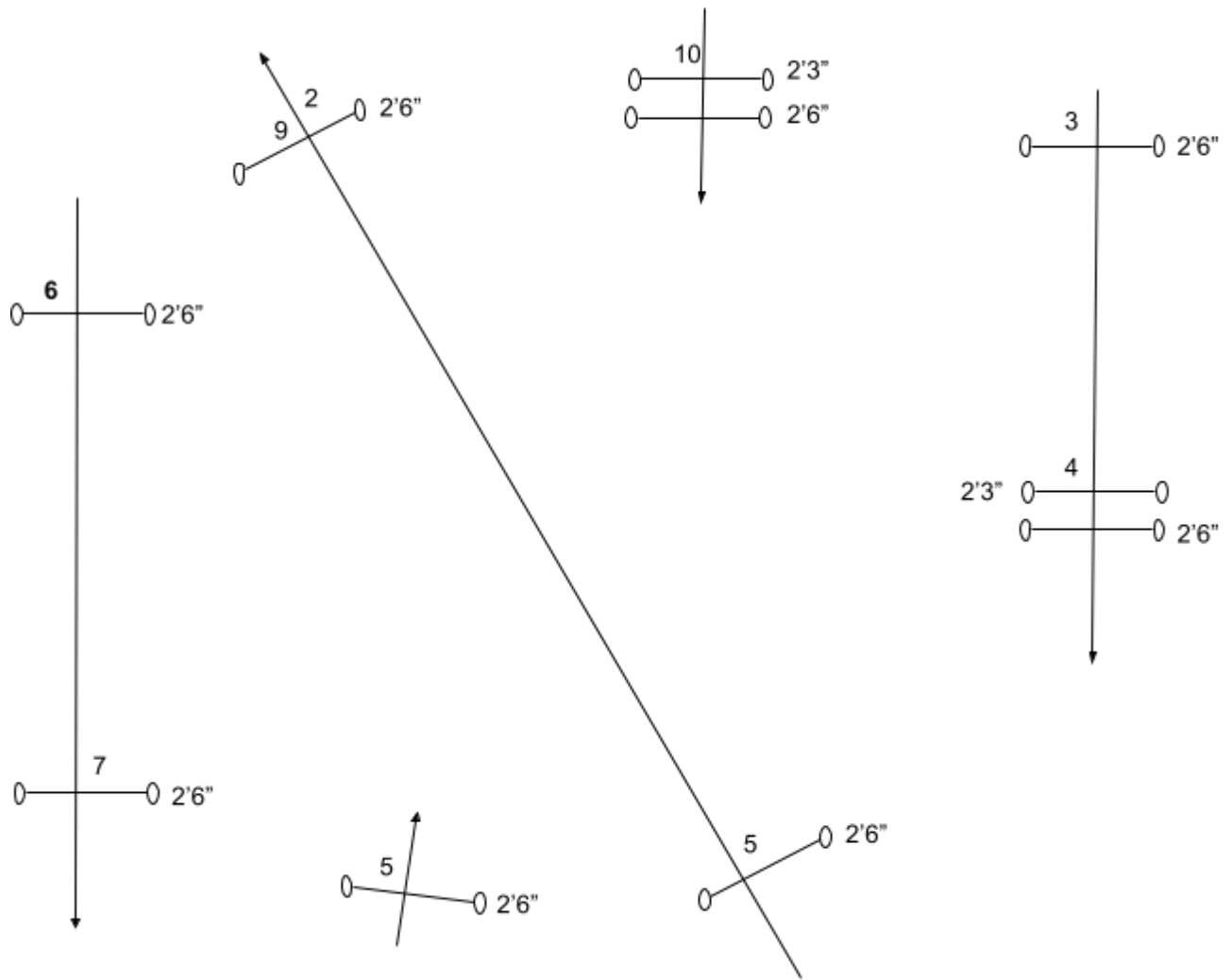

# HUNT SEAT MEDALS GOLD COURSE #1

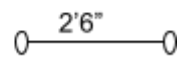
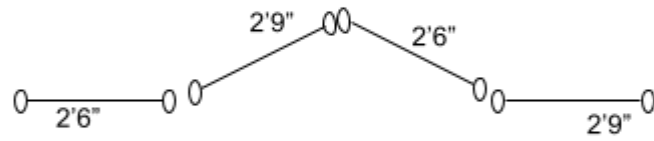
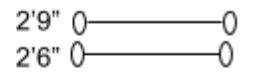
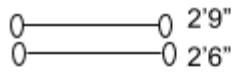

# HUNT SEAT MEDALS GOLD COURSE #2

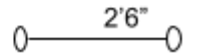
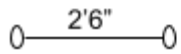
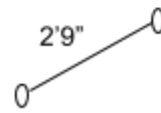
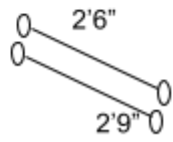
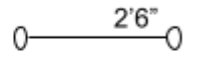
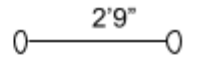
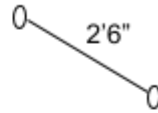
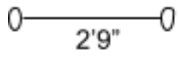

# HUNT SEAT MEDALS GOLD COURSE #3

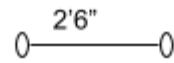
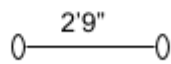
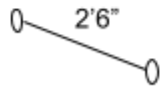
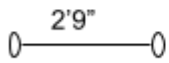
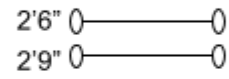
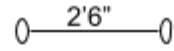
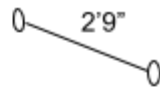
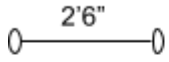



# HUNT SEAT MEDALS GOLD COURSE #4

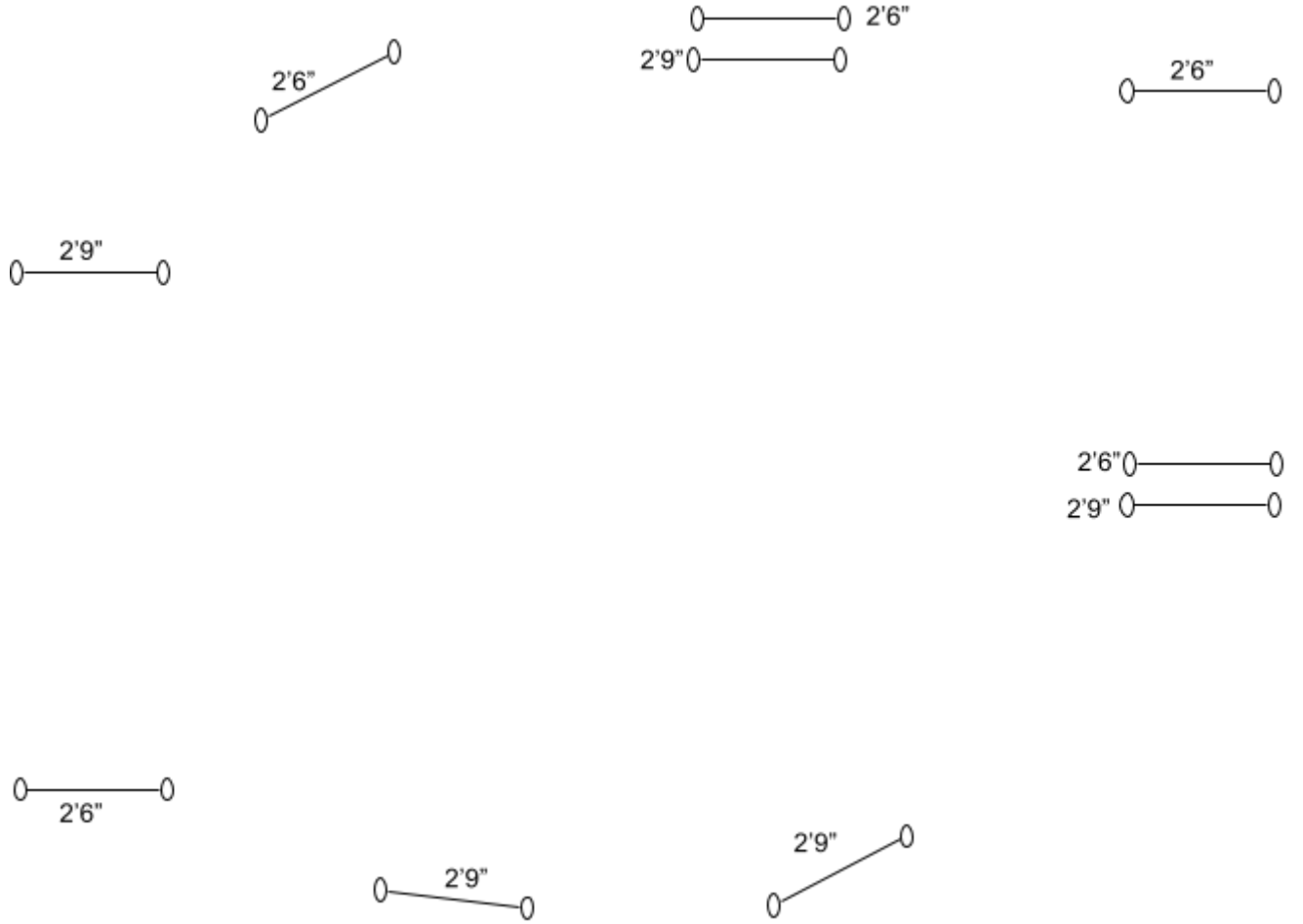

# HUNT SEAT MEDALS SUPREME COURSE #1

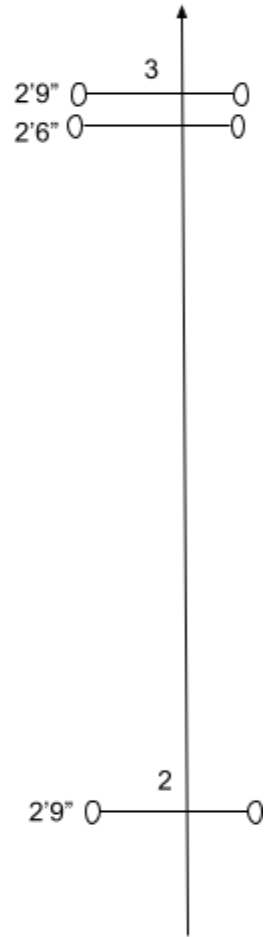
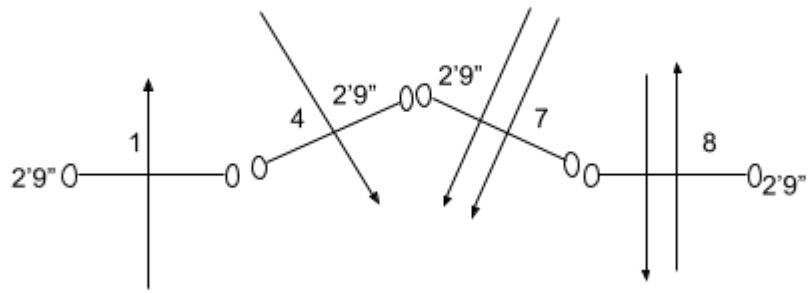
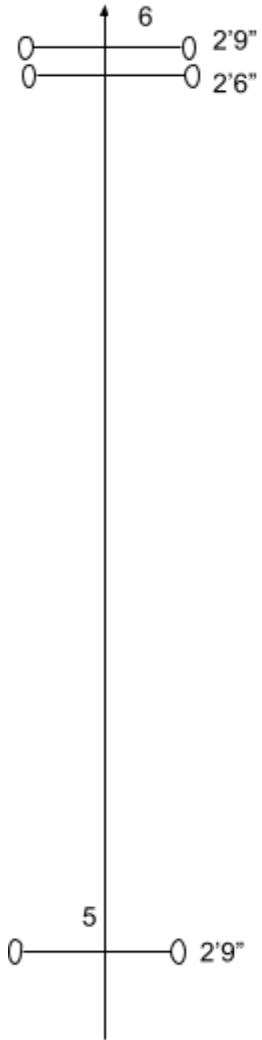

# HUNT SEAT MEDALS SUPREME COURSE #2

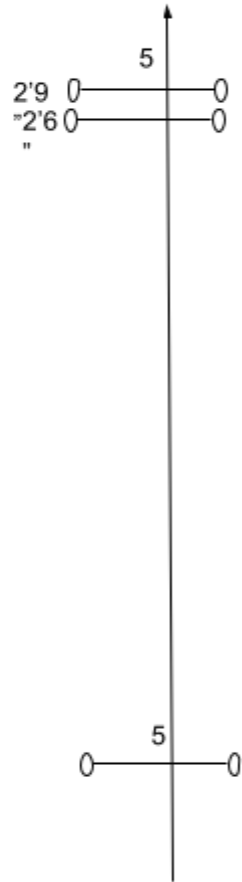
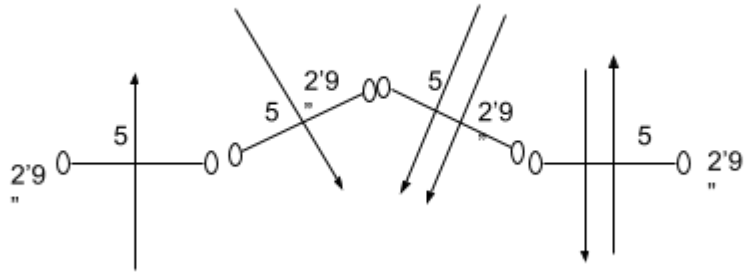
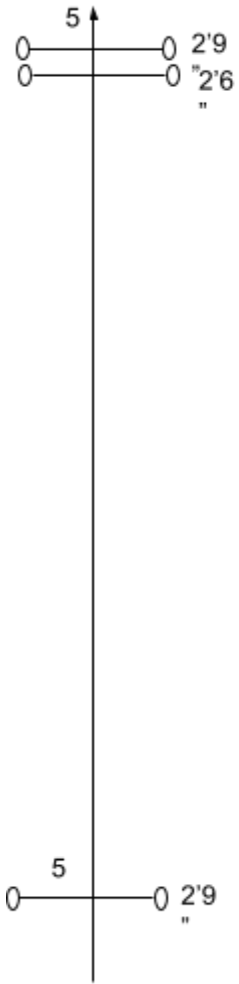

# HUNT SEAT MEDALS SUPREME COURSE #3

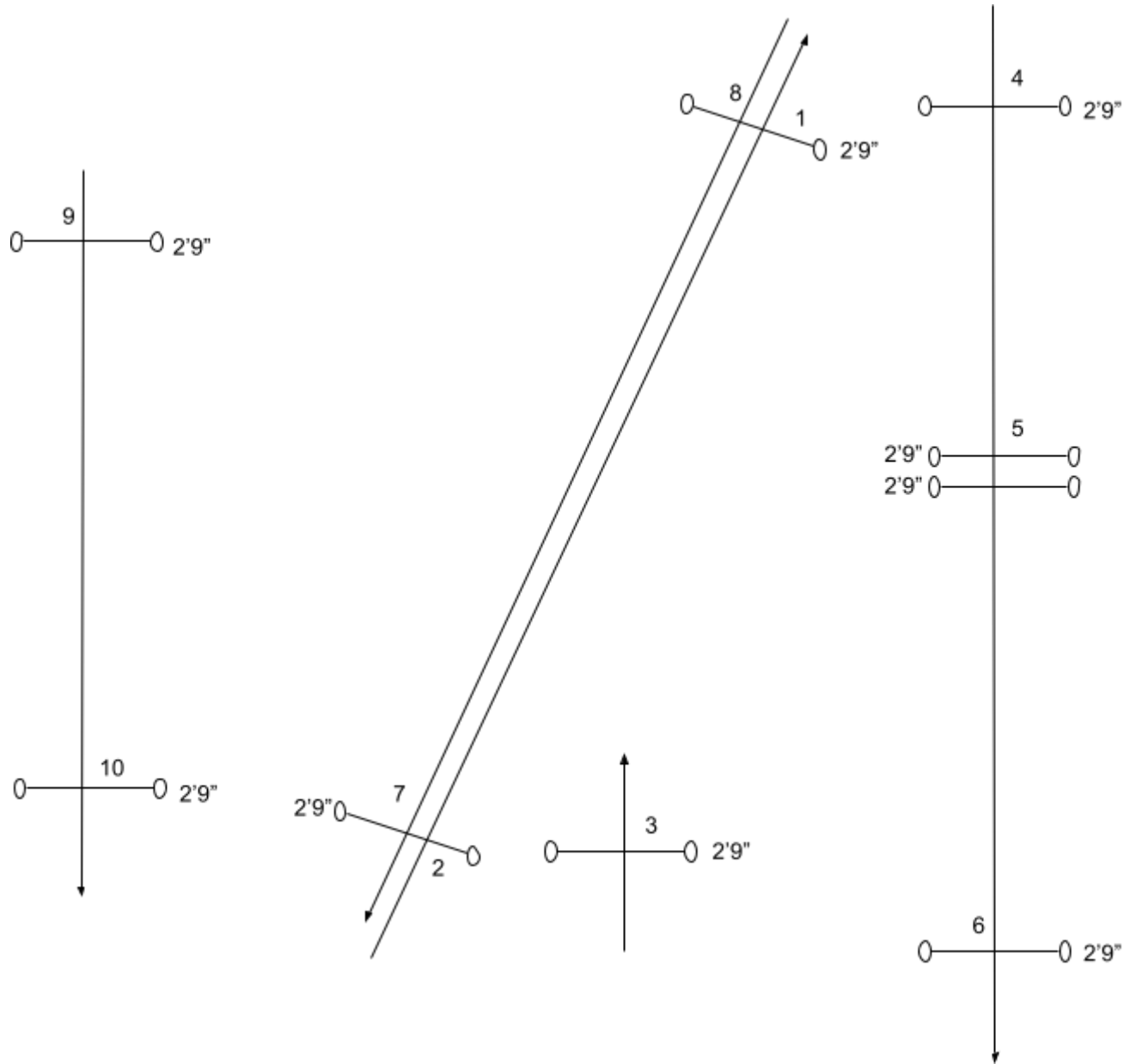

# HUNT SEAT MEDALS SUPREME COURSE #4

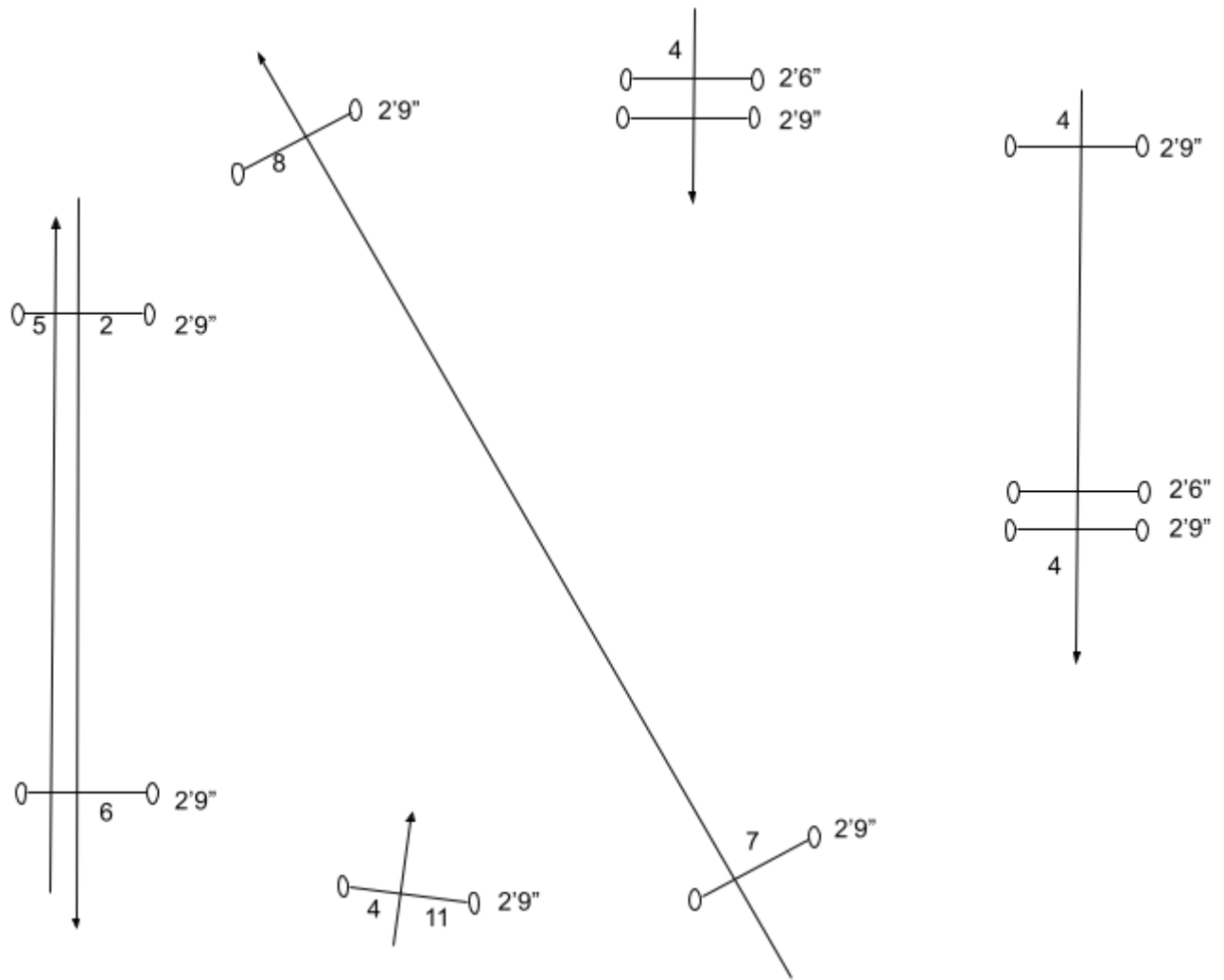

## DRESSAGE MEDAL AND SUPREME AWARD COMPETITION

- A. Current USEF and USDF dressage tests are used in 4-H dressage competition. These dressage tests are available on-line and are also sold in equestrian stores.
- B. To be eligible to ride for a Bronze Medal, a rider must earn 3 scores of 58% or above (danish blue at 3 separate shows) or a 60% (Dressage High Blue) or better on Training Level Test 1 or above. At King County Fair/qualifying event and other 4-H shows offering dressage classes, Danish ribbons will be awarded as follows:
  - a. 49.99% and under = White Danish
  - b. 50.00% through 57.99% = Red Danish
  - c. 58.00% and up = Blue Danish
  - d. 60% and up High Blue
- C. A rider can attempt their first Bronze attempt after qualifying as soon as the scores are released. Rider may NOT impose any schedule change or demand of early scoring on the show management. Rider may not enter the bronze class prior to qualifying for it. Only if scores are planned to be released prior to the riders next scheduled test being performed may the medals attempt at the same show be entered.
- D. The use of a reader will immediately disqualify the rider from any medals and state eligibility even if the score is earned and the medals fee is paid.
- E. Silver Medal competition is open to Bronze Medal winners. Gold Medal competition is open to Silver Medal winners. Supreme Medal competition is open to Gold Medal winners. A rider may win one Bronze, one Silver, one Gold, and as many Supreme Medals as he or she is capable of.
- F. Qualifications and percentages for each Medal will be as follows:
  - a. Bronze Medal: 61% and above in Training Level Test 2 and above
  - b. Silver Medal: 62% and above in Training Level Test 3 and above
  - c. Gold Medal: 63% and above in First Level Test 1 and above
  - d. Supreme Award: 63% on First Level Test 2 or above or First Level Freestyle will merit the awarding of one Supreme point. When an exhibitor has accumulated three Supreme points in Dressage, he or she will be eligible to receive a Dressage Supreme Award.
- G. Because King County 4-H shows do not offer dressage opportunities on a regular basis, members may qualify for dressage medals and also earn them by achieving the required scores at the State Fair or any dressage show outside 4-H that is judged by a USDF certified learner judge (or higher).
- H. Riders may qualify for the Dressage medal program at non 4-H shows in one of two ways:
  - a. Earning three danish blues with a score of 58% or higher at three different shows on TLT1 or above or
  - b. Earning a score of 60% or higher on TLT1 or above.
  - c. Complete the Dressage Medal electronic form to report scores
- I. To notify us that you plan to attempt a medal at non a 4-H show:
  - a. Fill out the Dressage Medals electronic form anytime prior to the start of the show, and pay the \$15 fee per attempt.
  - b. Payment may be a check made out to KC 4-H Horse Program and mailed in (to Lori Glasgow Medals Chair PO Box 1410 Buckley, WA 98321)
  - c. Or the Horse Program Venmo: @KCHorse4H
- J. As with every medal attempt for all disciplines, the medals fee must be paid whether the medal is earned or not.
- K. If the rider has earned a medal at a non 4-H show: Fill out the Dressage Medals electronic form that day if possible but within 5 days of the show.

- L. For the State Fair the rider does not have to fill out the electronic form prior to the event. If they earned the medal they simply fill out the Dressage Medals electronic form within 5 days of their section and pay the medals fee and they will receive their medal.
- M. If a rider believes they can qualify for their medals with their 1st test and earn their Bronze medal with their 2nd test at a single show;
  - a. They should complete the Dressage Medals electronic form at least 1 day prior to the show
  - b. Pay the \$15 either by check or Venmo
  - c. If the qualification is not earned the \$15 will be refunded
  - d. Complete the electronic form after the show to report scores as directed

## WESTERN GAMES MEDAL AND SUPREME AWARD COMPETITION

- A. Appointments: Must comply with requirements as stated in the *PNW 4-H Horse Contest Guide*. For situations not covered in the 4-H Horse Contest Guide, the older publication EM4610 *Western Games* may be consulted as a support manual. [Note: EM4610 is no longer available through WSU Extension.]
- B. Western Games exhibitors may qualify for and earn Showmanship Medals based on the same requirements as Performance exhibitors. See GENERAL RULES, section B. The Games Medals coordinator and the Performance Medals coordinator work together to maintain records of qualified exhibitors and Supreme Award points.
- C. Riders qualify for the Western Games Medals in running events by running a Medals qualifying time. Medals qualifying times are as follows: or run 3 danish blue times for an event.

Event	Key	Poles	Figure 8	2 Barrel	Intl Flags	Barrels
Qual time	10.000	24.500	20.700	10.500	9.500	17.500

- D. After initial qualifying, riders may sign up for Medals runs at gaming shows which offer running Medals. A Medals class fee will be charged. Exhibitors will be allowed to have either of their regular runs count as medals runs if the Medals fee has been paid.
- E. To earn a medal at the state fair; rider must complete the letter of intent, pay the fee, and turn it in by the deadline on the form, to be eligible to earn the medal at the state fair. Rider and parent should not approach the horse barn office to obtain time documentation. Follow state rules for this.
- F. Medals runs will be offered at no cost at King County Fair/qualifying event or at a single show each show season designated by the Western Games Chair in consultation with the Games Medals chair.
- G. Medals must be earned in order. For each event, the Bronze Medal must be earned before earning Silver, Silver before Gold, and Gold before Supreme.
- H. A rider earns a Medal when the official time for the Medal run is less than the required time for earning the Medal. Medals times are shown in the following table (all times are in seconds):

EVENT	BRONZE	SILVER	GOLD	SUPREME
Key	9.500	9.000	8.700	8.500
Pole Bending	24.000	23.500	23.000	22.500
Figure 8	20.200	19.700	19.200	18.700
2 Barrel Flags	10.000	9.500	9.000	8.700
Intl Flags	9.000	8.750	8.5	8.25
Barrels	17.000	16.500	16.000	15.400